

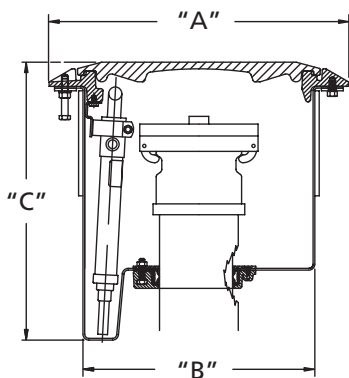

**EBW's 702, 703, 705, 715 & 725 Series
FlexCatch® Grade Level Spill Containers**

EBW's FlexCatch® spill containers are designed to collect spilled product that occurs during normal tank filling on underground storage tanks. Threaded base models are available in cast iron or composite. Slip-On (Retrofit) models use a gasket flanged bolt system to secure the spill bucket to the riser pipe and are designed to eliminate the need to remove the riser pipe from the underground tank when installing.

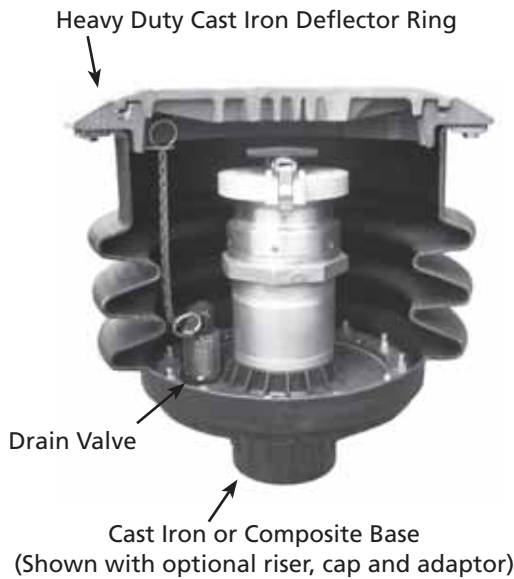

**702/703
SLIP-ON BASE**

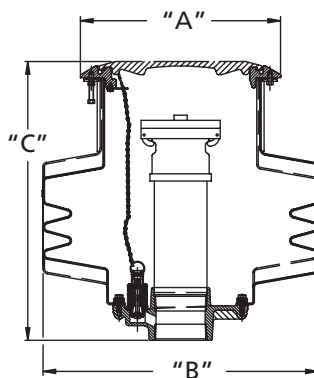

**705/715/725
THREADED BASE**

PART	A		B		C	
	IN.	CM.	IN.	CM.	IN.	CM.
702/703	17.12	43.48	13.25	33.70	15.88	40.30
705	17.12	43.48	14.75	37.46	15.69	39.85
715	17.12	43.48	23.50	59.69	22.50	57.15
725	17.12	43.48	24.40	68.58	27.00	68.58

Design Highlights & Advantages

- **Solid Construction** - the durable and flexible polyethylene shell is designed to move with natural ground movements. The shell is equipped with a gravel guard to prevent backfill material from filling in around the movable shell, eliminating problems with ground movement.
- **Cast Iron or Composite Base** - ensures a long lasting, watertight seal.
- **Heavy Duty Cast Iron Deflector Ring** - provides protection from heavy traffic and truck plows and allows for water to run away from the spill container top, eliminating water collection in the bucket.
- **Drain Valve** - allows emptying of contained product back to the storage tank. The drain is equipped with a screen for convenient cleaning.
- **Cover Options** - includes FRC rain tight in API colors, FRC black snap-on, rain tight aluminum, watertight locking aluminum and cast iron.
- **Optional API Cover Identification Plates** - clearly identifies the product contained in the storage tank and helps to prevent cross contamination. Identification plates are available for all standard API symbols.
- **Highway 20 Rated (D.O.T. H20)** - all EBW spill containers and manholes exceed the D.O.T. H20 requirements.

Certifications/Listings

- * EVR Phase 1 Certification VR-103
- * Biofuel Approved (E85 and biodiesel)

MATERIALS

Base: Cast iron or composite

Bucket: Polyethylene or stainless steel (703)

Mounting Ring: Cast iron

Cover: Fiber Reinforced Composite (FRC), cast iron or aluminum

EBW's 702, 703, 705, 715 & 725 Series FlexCatch® Grade Level Spill Containers



Retrofit



Threaded Base



Cover Options



Watertight Aluminum Lock Down Cover with Identification Plate



702
5 gal. (19 liter)



703
5 gal. (19 liter)



705
5 gal. (19 liter)



715
15 gal. (27 liter)



725
25 gal. (95 liter)

Grade Level Spill Containers with Cast Iron Base



Cast Iron Base

PART	GALLON	LITER	COVER/SPECIAL	LBS.	KG.
With Drain					
705-470-01-BLK	5	19	GL with black FRC cover	54	25
705-472-01-BLK-5	5	19	Black snap-on cover, MB, P/P	54	25
705-479-65-CI-GKT	5	19	Cast iron cover with handle, riser, cap and adaptor, MB, P/P, GKT	56	25.4
705-479-65	5	19	P/P, MB, COV, ASSY	58	26.7
705-479-66	5	19	P-P, COV, MB, CANADIAN	56	25.4
705-490-01-BLK	5	19	MB, 70542301 BLK COV	58	26.7
715-470-01-BLK	15	57	MB, P/P, RT, BLK	62	28
715-472-66-BLK	15	57	NYC, PULL-PUSH, MB, SO, COV	62	28.5
725-470-01-BLK	25	95	MB, P/P, RT, BLK	92	42.3
Without Drain					
705-458-01-BLK	5	19	MB, RT, BLK, 70542301 BLK COV	64	29.4
705-483-01	5	19	C.I. COV, MB, ASSY	68	30.8
705-488-01-BLKS	5	19	MB, NO COV, 705-333-01 BLK SNAP COV	62	28
705-490-02-BLK	5	19	MB, NO RT COV, 70542301 BLK COV	42	19.3

Note: Additional cover options provided on next page.



Grade Level Spill Containers

Composite Base

PART	GALLON	LITER	COVER/SPECIAL	LBS.	KG.
With Drain					
705-471-01-BLK	5	19	CB, P/P, RT, BLK	42	19.3
705-473-01-BLKS	5	19	CB, P/P, SO, BLK-S	42	19.3
715-471-01-BLK	15	57	CB, P/P, RT, BLK	50	23

Retrofit Spill Containers

PART	GALLON	LITER	COVER/SPECIAL	LBS.	KG.
With Pump					
702-400-01-BLK	5	19	RETRO, 5 GL, RT, BLK	34	15.6
702-404-65-CI-GKT	5	19	RETRO, 5 GAL (CAN), CI-GKT	33	15.1
702-405-01-BLK-S	5	19	RETRO, 5 GAL, SO, BLK-S	33	15.1
702-405-65-BLK	5	19	RETRO, 5 GAL (CAN), SO, BLK		
703-400-01-BLK	5	19	RETRO, 5 GAL, RT, SS, BLK	45	20.4
Without Pump					
702-404-NP	5	19	RETRO, 5 GAL (CAN), NC	37	16.8
702-404-NP-CI-GKT	5	19	RETRO, 5 GAL (CAN) CI-GKT	37	16.8
702-406-01-BLK	5	19	RETRO, 5 GAL, RT, BLK	37	16.8

Rain Tight Cover Options

SUFFIX	DESCRIPTION	SUFFIX	DESCRIPTION
BLK	Black, Rain tight	BRN	Brown, Rain tight
WHT	White, Rain tight	WHT-X	White, Rain tight with black cross
RED	Red, Rain tight	RED-X	Red, Rain tight with white cross
BLU	Blue, Rain tight	BLU-X	Blue, Rain tight with white cross
YEL	Yellow, Rain tight	CI-GKT	Cast iron with gasket
GRY	Gray, Rain tight	CI	Cast iron
ORG	Orange, Rain tight	ALUM	Aluminum
GRN	Green, Rain tight	WATERT	Watertight (Aluminum)

Note: You must specify cover option at time of order.



12" Replacement Covers for Grade Level Spill Containers

PART	DESCRIPTION
705-430-00	Cast iron
705-409-00	Aluminum
705-440-01	Cast iron with gasket
705-420-02	FRC - White with black cross, Regular Unleaded
705-420-03	FRC - Red with white cross, Premium Unleaded
705-420-04	FRC - Blue with white cross, Mid-Grade Unleaded
705-423-01	FRC - Standard black cover
705-423-02	FRC - White
705-423-03	FRC - Red
705-423-04	FRC - Blue
705-423-05	FRC - Yellow
705-423-06	FRC - Grey
705-423-07	FRC - Orange
705-423-08	FRC - Green
705-423-09	FRC - Brown
705-333-01	FRC Snap-on - Black*
710-430-01	Aluminum watertight with bracket for use on 705, 715 and 725 GL Spill Containers
705-171-01	Replacement clips for snap-on covers

*Note: Snap-on lids only fit on special snap-on spill containers. Please consult factory. Minimum quantities may apply.