

AV GASKET



Full face Type Rubber Gasket



Ring Type Gasket (JIS only)



PTFE coated



PVDF coated

● MATERIAL : EPDM, PTFE, PVDF, CSM, FKM, IIR, Viton F, C

FEATURES

- AV GASKETS offer Similar sealing performance with 1/3 bolt tightening torque, compared to flat or envelope style gaskets.
- Uniform dimension, fine surface, suitable hardness.
- Long service life.
- Unique Convex Design.

SPECIFICATIONS

Material	Working Temperature	SIZE AVAILABILITY BY STANDARD		
		JIS	ANSI	DIN
EPDM	-40°C - 90°C (-40°F - 195°F)	15mm - 350mm	1/2inch - 16inch *1	15mm - 350mm
PTFE	-40°C - 120°C (-40°F - 250°F)	15mm - 300mm	1/2inch - 12inch	15mm - 300mm
PVDF	-40°C - 120°C (-40°F - 250°F)	15mm - 300mm	1/2inch - 10inch *2	15mm - 300mm
VIFLON	-5°C - 150°C (-5°F - 280°F)	15mm - 200mm	-	-

Working temperature is different depending on type of fluid.

Voflon-F has superior resistance to inorganic acids such as HNO₃, HF and HCl.

Voflon-C has superior resistance to chlorine containing media such as Chlorine Water, NaCl and ClO₂.

* 1 14inch, 16inch: FLAT FULL FACE

* 2 Except for 1 1/4inch and 2 1/2inch

DIMENSIONS

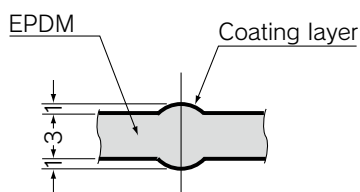
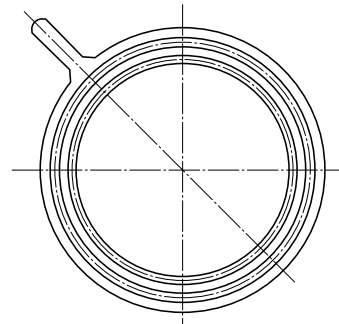
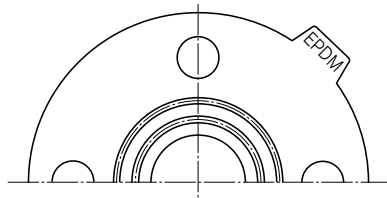
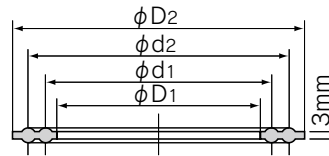
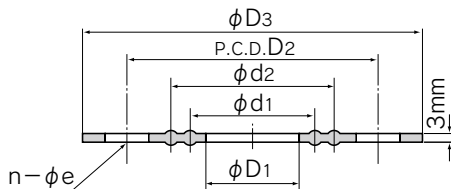

Type	Nominal Size	Thickness
PTFE	15mm(1/2inch) to 300mm(12inch)	0.3-0.4mm(0.012-0.016inch)
PVDF	15mm(1/2inch) to 65mm(2 1/2inch) 80mm(3inch) to 300mm(12inch)	0.4-0.5mm(0.016-0.020inch)

DIMENSIONS TABLE

Full-Face Type (JIS 10K)								Unit:mm
Nominal Size		D ₁	D ₂	D ₃	n	e	d ₁	d ₂
mm	inch							
13	3/8	15	65	88	4	15	22	37
15	1/2	18	70	93	4	15	26	41
20	3/4	22	75	98	4	15	32	47
25	1	30	90	123	4	19	38	53
32	1 1/4	37	100	133	4	19	50	65
40	1 1/2	43	105	138	4	19	54	69
50	2	54	120	153	4	19	68	83
65	2 1/2	69	140	173	4	19	86	101
80(75)	3	80	150	183	8	19	98	112
100	4	102	175	208	8	19	120	138
125	5	127	210	248	8	23	145	166
150	6	150	240	278	8	23	168	190
200	8	198	290	328	12	23	216	247
250	10	249	355	398	12	25	270	306
300	12	300	400	443	16	25	324	352
350	14	350	445	488	16	25	370	390

Ring Type (JIS 10K)						Unit:mm
Nominal Size		D ₁	D ₂	d ₁	d ₂	
mm	inch					
15	1/2	18	54	26	41	
20	3/4	22	59	32	47	
25	1	30	70	38	53	
32	1 1/4	37	80	50	65	
40	1 1/2	43	85	54	69	
50	2	54	100	68	83	
65	2 1/2	69	120	86	101	
80(75)	3	80	130	98	112	
100	4	102	155	120	138	
125	5	127	187	145	166	
150	6	150	217	168	190	
200	8	198	267	216	247	
250	10	249	329	270	306	
300	12	300	374	324	352	

Full-Face Type (DIN 2501)								Unit:mm
Nominal Size		D ₁	D ₂	D ₃	n	e	d ₁	d ₂
mm	inch							
15	1/2	18	65	93	4	14	26	41
20	3/4	22	75	103	4	14	32	47
25	1	30	85	113	4	14	38	53
32	1 1/4	37	100	138	8	18	50	65
40	1 1/2	43	110	148	4	18	54	69
50	2	54	125	163	4	18	68	83
65	2 1/2	69	145	183	4	18	86	101
80(75)	3	80	160	198	8	18	98	112
100	4	102	180	218	8	18	120	138
125	5	127	210	248	8	18	145	166
150	6	150	240	283	8	23	168	190
200	8	198	295	338	8	23	216	247
250	10	249	350	393	12	23	270	306
300	12	300	400	443	12	23	324	352
350	14	350	460	503	16	25	370	390

Full-Face Type (ANSI CLASS150)								Unit:inch
Nominal Size		D ₁	D ₂	D ₃	n	e	d ₁	d ₂
inch	mm							
1/2	15	0.7	2.4	3.4	4	0.6	1.0	1.6
3/4	20	0.9	2.8	3.8	4	0.6	1.3	1.9
1	25	1.2	3.1	4.2	4	0.6	1.5	2.1
1 1/4	32	1.5	3.5	4.5	4	0.6	2.0	2.6
1 1/2	40	1.7	3.9	4.9	4	0.6	2.1	2.7
2	50	2.1	4.7	5.9	4	0.8	2.7	3.3
2 1/2	65	2.7	5.5	6.9	4	0.8	3.4	4.0
3	80(75)	3.2	6.0	7.4	4	0.8	3.9	4.4
4	100	4.0	7.5	8.9	8	0.8	4.7	5.4
5	125	5.0	8.5	9.9	8	0.9	5.7	6.5
6	150	5.9	9.5	10.9	8	0.9	6.6	7.5
8	200	7.8	11.8	13.4	8	0.9	8.5	9.7
10	250	9.8	14.3	15.9	12	1.0	10.6	12.1
12	300	11.8	17.0	18.9	12	1.0	12.8	13.9
14	350	13.9	18.7	20.9	12	1.14	14.6	15.4
16	400	15.6	21.2	23.4	16	1.14	17.3	18.5

* 1 14inch, 16inch: FLAT FULL FACE

RECOMMENDED TIGHTENING TORQUE <ALL MATERIALS / FULL FACE TYPE>

mm(inch)	N·m	FT-LB	mm(inch)	N·m	FT-LB	mm(inch)	N·m	FT-LB
15 (1/2)	17.5	13	65 (2 1/2)	22.5	16	200 (8)	55	40
20 (3/4)	17.5	13	80 (3)	30	22	250(10)	55	40
25 (1)	20	14	100(4)	30	22	300(12)	60	43
40 (1 1/2)	20	14	125(5)	40	29	350(14)	60	43
50 (2)	22.5	16	150(6)	45	32	400(16)	80	58