

To avoid any dangerous spark between a component and the tank during loading operation the tank must be earthed. The "DCMT 3" basic function is to earth automatically the tank to the ground to avoid any operator error.

♦ EEx explosion proof and intrinsec safety electronic board. EExd (ia) ia II C T6.
♦ Waterproof IP 67 (CEI 60529)
♦ Programmable system: the user can change the set up values for electrical recognition.
♦ Value of resistance and capacitance limits are programmable
♦ Numerical model (intel 386 processor)
♦ System safety, high insulation voltage relay (10.000 V), self checking relay conditions
♦ Working temperature: -40 °C / +60 °C
♦ Material: Aluminium casting Al-Si7Mg0,3
♦ Homologation by LCIE Certificate No. 00.E6088X In accordance with standard EN 50.014



Weight: 15.2 kg

### Working cycle

The clamp is connected to the tank.

The system detects the good clamp connection and the grounding relay connects the tank to earth.

The system measures the electrical signature and compare it to set values, if the values are in the right range the output relays and green light are activated to allow the loading.

During the loading, the good connection to earth is monitored and the system stops the loading if a disconnection occurs.

When loading is completed, the connecting clamp is disconnected, the grounding relay opens and waits for next connection, during this time, the grounding relay is monitored to check its status (it is dangerous to connect a clamp with a relay in shut position).

### DCMT 3 main applications

- Tank truck earthing
- Barrel earthing
- Wagon earthing

The site specific electrical signatures are "pre set" during the manufacture and if necessary it is possible to be controlled externally.

The application should be determined when ordering.

### DCMT 3 main advantages

- Self checking in case of breakdown or unprofessional connection.
- History of last events / connections / in system memory useful to check in case of problem.  
Redundant output relays and continuously monitored.
- Set up parameters adaptable according to site installation.

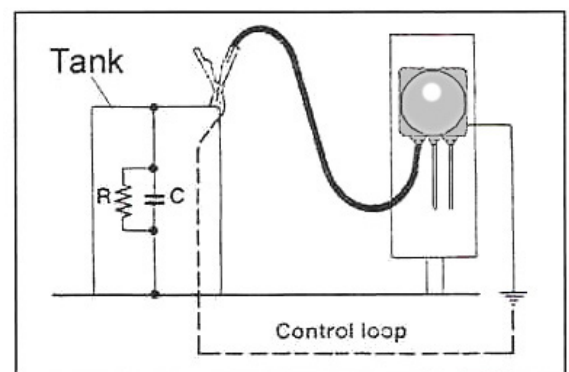

## NORMAL PROCEDURE

- Check if the leds are not in an alarm condition.
- Connect clamp to the tank
- Wait maximum 5 seconds to get the 7 green leds signal which allows loading
- When loading is completed, disconnect the clamp from the tank and bring it back to it's fixture

## FORCED PROCEDURE

For site supervision only

When loading is not allowed (7 red leds and one fix green led), the bypass key can be used to allow loading.

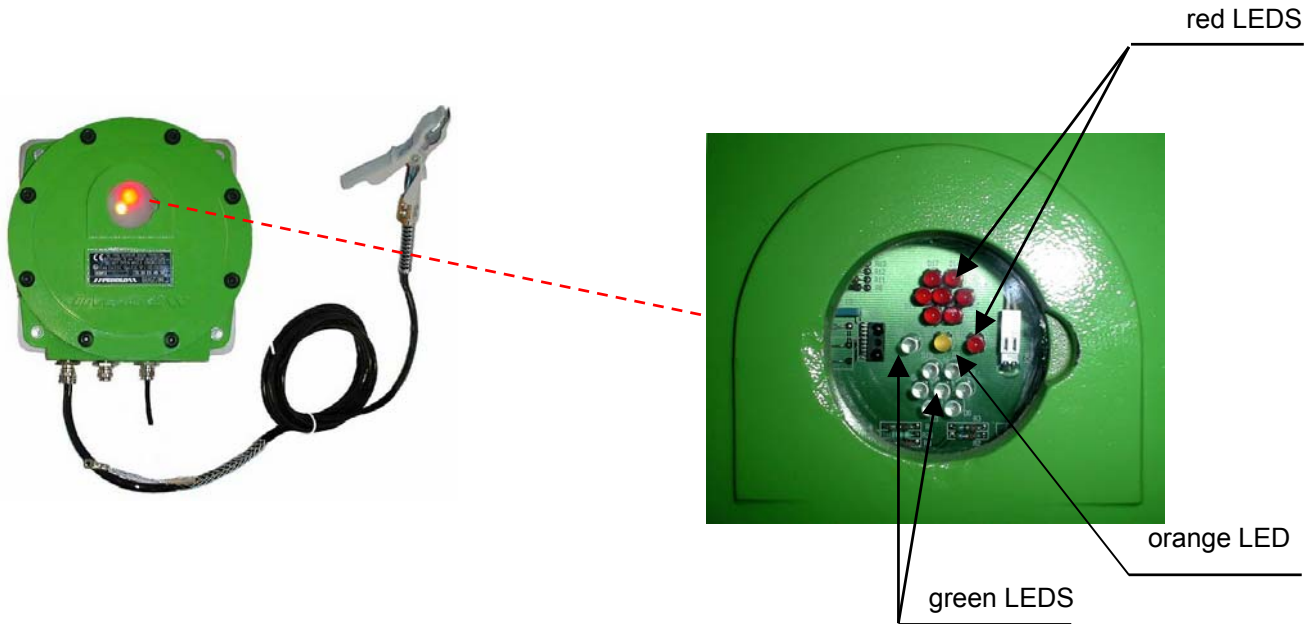

LED signals signification:

- |  |   |  |
|--|---|--|
| One green led flashing and group of 7 leds fix red | → | ready for connection   |
| One green led fix and group of 7 leds fix red      | → | grounding of tank has occurred<br><b>Not</b> allowed to load: tank parameters out of set up values |
| One green led fix and group of 7 leds fix green    | → | allowed to load: tank parameters within set up values  |
| <b>All flashing red leds</b>                       | → | <b>ALARM</b>   |

**If this occurs before clamp connection:**

**DO NOT CONNECT THE CLAMP TO THE TANK: THE ALARM SHOWS AN INTERNAL DEFECT OF THE UNIT, THE CONNECTION TO THE TANK COULD BE HAZARDOUS**

**EMCO WHEATON**  
A Gardner Denver Company

DCMT\_3\_e WSP/hsc

Whilst the content of this leaflet has been edited with the greatest care, we are not liable for any errors or omissions

**EMCO WHEATON**  
GmbH

Emcostr. 2 – 4 D - 35274 Kirchhain, Germany  
Tel.: +49 (0) 6422 84- 0    ♦ Fax : +49 (0) 6422 5100  
sales@emcowheaton.com    ♦ www.emcowheaton.de