

Composite Manhole Covers

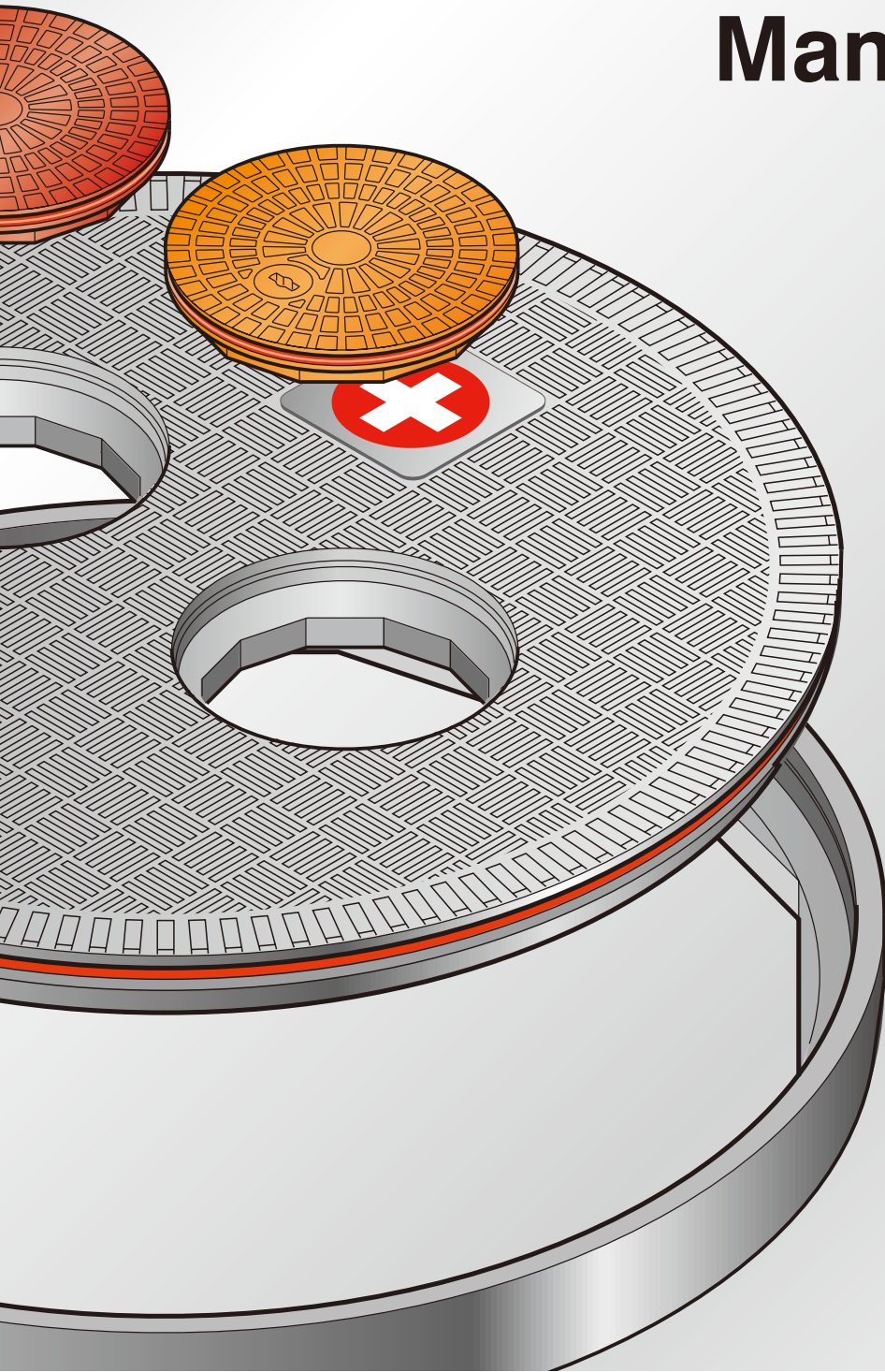

Shaping future standards

One Superior Standard - No cracking, no delamination, no deflection or permanent set,

Watertight Flat Sealed Covers

The leading watertight, easy to remove, non-bolting composite manhole cover on the market is available in a range of sizes and load ratings.

FL100 and FL90 models are suitable for turbine sump access. The small FL120 model is ideal for single ATG or manual dip points on the tank, or to cover monitoring wells. Locks available.



Product Code	Description
FL100	40" dia. flat sealed cover and composite frame
FL90	36" dia. flat sealed cover and composite frame
FL90/HD	36" dia. heavy duty flat sealed cover and composite frame
FL120	12" dia. flat sealed cover and composite frame

Raised Covers

The original raised cover, designed with a simple water check in the frame, to keep rainwater out of the installation. This cover is not sealed, so excess surface water can drain into the ground between the skirt and sump. Still an award winning design, this cover range offers a cost effective solution for all sump access installations. Locks available.

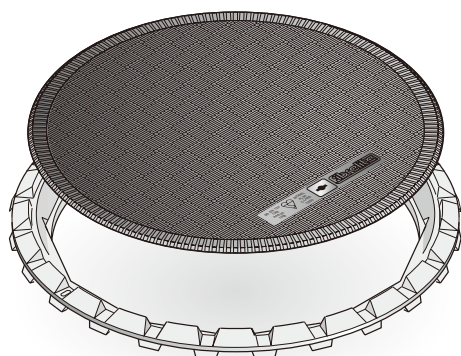

Product Code	Description
FL42	42" dia. raised cover and aluminium frame
FL42/HD	42" dia. heavy duty raised cover and aluminium frame
FL36	36" dia. raised cover and aluminium frame
FL36/HD	36" dia. heavy duty raised cover and aluminium frame

Contact Fibrelite if steel frame is required.

anti-static, slip resistant, they will not spin out and have 'injury free' single person ergonomic removal

New Multi-Port Covers

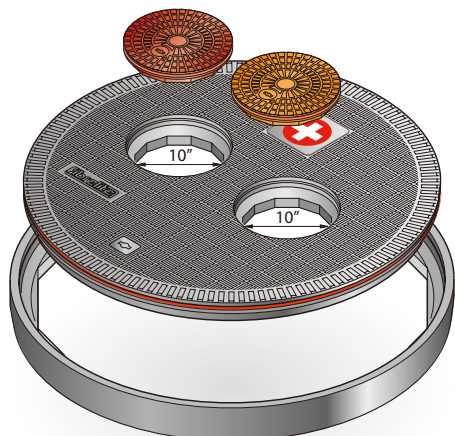

A break-through in composite technology enabled the launch of our new premium range of multi-port covers. Our lightweight composite, non-bolting covers, include two ports to give direct access to fill and vapor recovery or dip risers inside the tank sump. Ports are located at 16" centers and can be color coded to identify the fuel grade and are attached with a chain to prevent incorrect fuel drops into the tank. Additional product ID plates can be fixed to the main cover. The tough, hard wearing material ensures the user has a high performing, long lasting product. Designed and tested to comply with DOT H20 axel loading.

Product Code Description

FL100/MP	40" dia. flat sealed multi port cover and composite frame
FL90/MP	36" dia. flat sealed multi port cover and composite frame

Single Fill Port Covers

This optional range of fill port covers are designed with only one hole, for access to one fill riser. The port is located in a central or offset position and the port cover can be color coded to identify the fuel grade. The port cover is attached with a chain to prevent incorrect fuel drops into the tank. Additional product ID plates can be fixed to the main cover. Hole position varies on each size of cover.

FL90 - 36" dia. Fill Covers

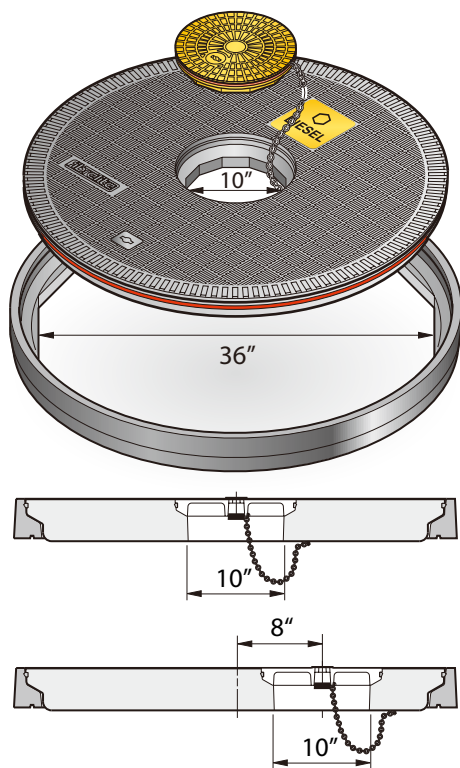

FL100 - 40" dia. Fill Covers

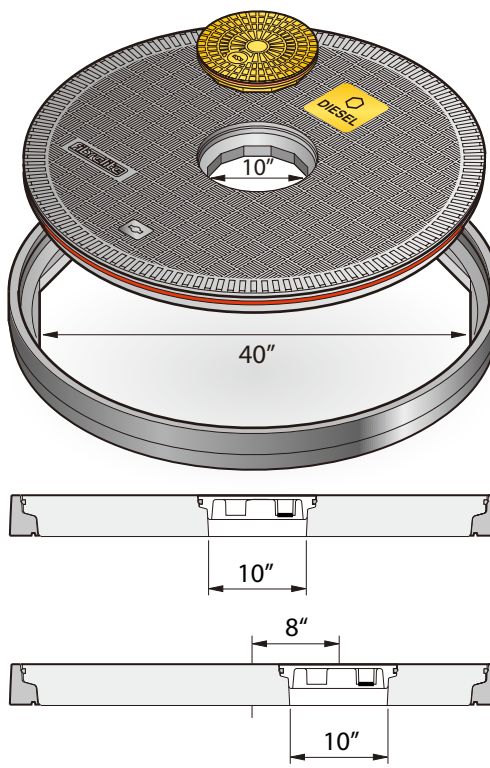

Product Code Description

FL90/CF	36" dia. cover with central fill cap
FL90/OF	36" dia. cover with offset fill cap

Product Code Description

FL100/CF	40" dia. cover with central fill cap
FL100/OF	40" dia. cover with offset fill cap

Covers supplied with a composite frame.

Manual Dip Port Covers

This range of covers has been designed for tank sump installations where the manual dip is located on the tank manway; either central or offset. You still get the same high performance lightweight Fibrelite cover, with quick, easy and safe access to the manual dip pipe. The dip cover can be chained to the main cover for security and can be color coded to the fuel grade. Additional product ID plates can be fixed to the main cover.

FL90 - 36" dia. Dip Covers

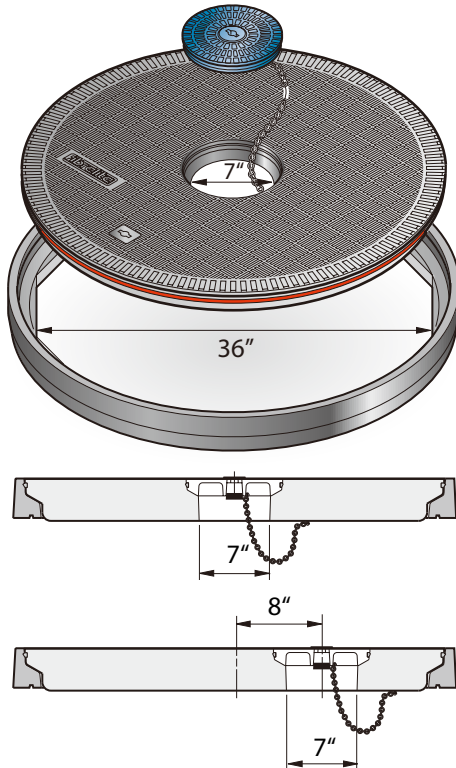

FL100 - 40" dia. Dip Covers

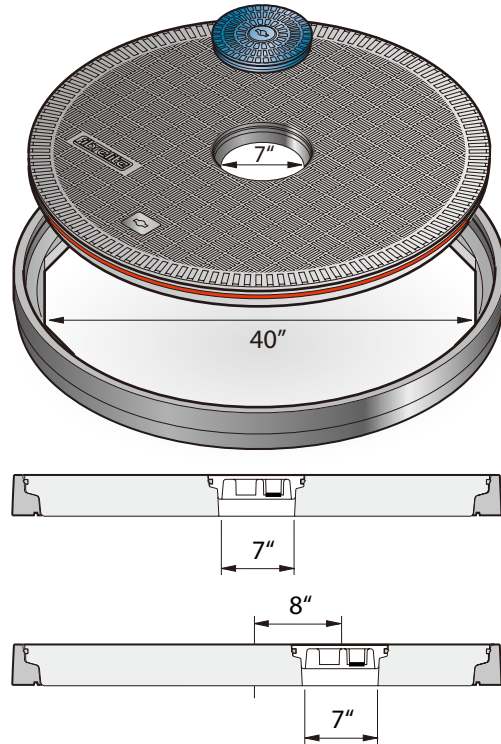

Product Code	Description	Product Code	Description
FL90/CD	36" dia. cover with central dip cap	FL100/CD	40" dia. cover with central dip cap
FL90/OD	36" dia. cover with offset dip cap	FL100/OD	40" dia. cover with offset dip cap

Covers supplied with a composite frame.

Square Watertight Flat Sealed Covers

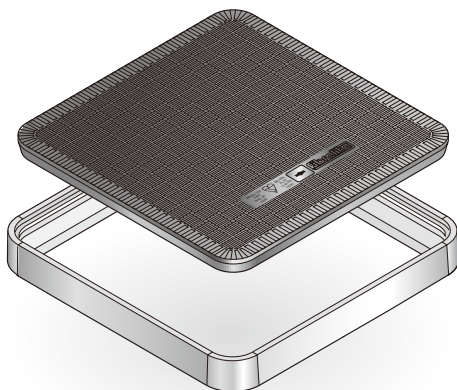

An alternative design to our round cover, the square cover is designed to cover general pits on the gas station or for any industrial application. The leading watertight, easy to remove, non-bolting composite manhole cover on the market is available in a range of sizes and load ratings. Locks available.

Product Code	Description
FL76	30" square flat sealed cover and aluminum frame
FL76/HD	30" square heavy duty flat sealed cover and aluminum frame
FL60	24" square flat sealed cover and aluminum frame
FL60/HD	24" square heavy duty flat sealed cover and aluminum frame
FL450	18" square flat sealed cover and aluminum frame
FL450/HD	18" square heavy duty flat sealed cover and aluminum frame

Cover Accessories - FRP Skirts

FRP skirts manufactured using high technology RTM production methods, to create a one piece, smooth-finish skirt. Skirts supplied factory bonded to the frame, or loose with sealant.

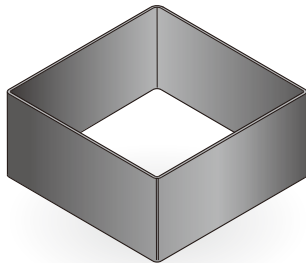
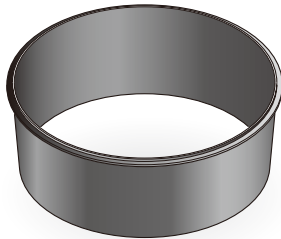
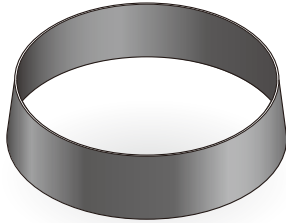

FRP Flared Skirts

Model	Description
FL90/SK10	10" deep flared skirt to fit FL90 models
FL36/SK10	10" deep flared skirt to fit FL36
FL36/SK12	12" deep flared skirt to fit FL36
FL42/SK10	10" deep flared skirt to fit FL42
FL42/SK12	12" deep flared skirt to fit FL42
FL42/SK18	18" deep flared skirt to fit FL42
FL100/SK10	10" deep flared skirt to fit FL100 models

FRP Straight Skirts

Model	Description
FL90/SK10/S	10" deep skirt to fit FL90 models
FL90/SK12	12" deep skirt to fit FL90 models
FL120/SK12	12" deep skirt to fit FL120

FRP Square Skirts

Model	Description
FL76/SK12	12" deep square skirt to fit FL76
FL60/SK24	24" deep square skirt to fit FL60
FL450/SK24	24" deep square skirt to fit FL450

ID Plates



6" square adhesive backed product ID plates to fit in the cover recess.

Model	Description
FL-FRP-IDV	SHELL V POWER
FL-FRP-IDP	Premium
FL-FRP-IDR	Regular
FL-FRP-IDM	Mid-grade
FL-FRP-IDD	Diesel
FL-FRP-ULSD	Ultra-low sulfur diesel
FL-FRP-IDK	Kerosene
FL-FRP-CSE	Confined space entry
FL-FRP-IDF	Custom made plates

Locks and Seal replacement kits are also available.

Lifting Handles

FL7

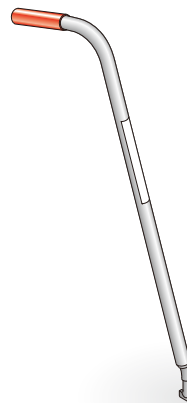

To easily and safely remove and replace raised covers.

FL7A

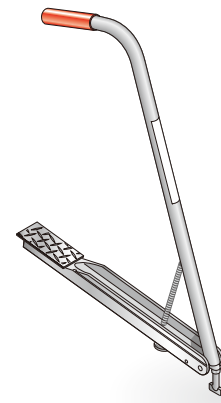

With foot lever designed to break the seal on watertight flat sealed covers.



Fibresec
GROUP
COMPANY



FM 37923

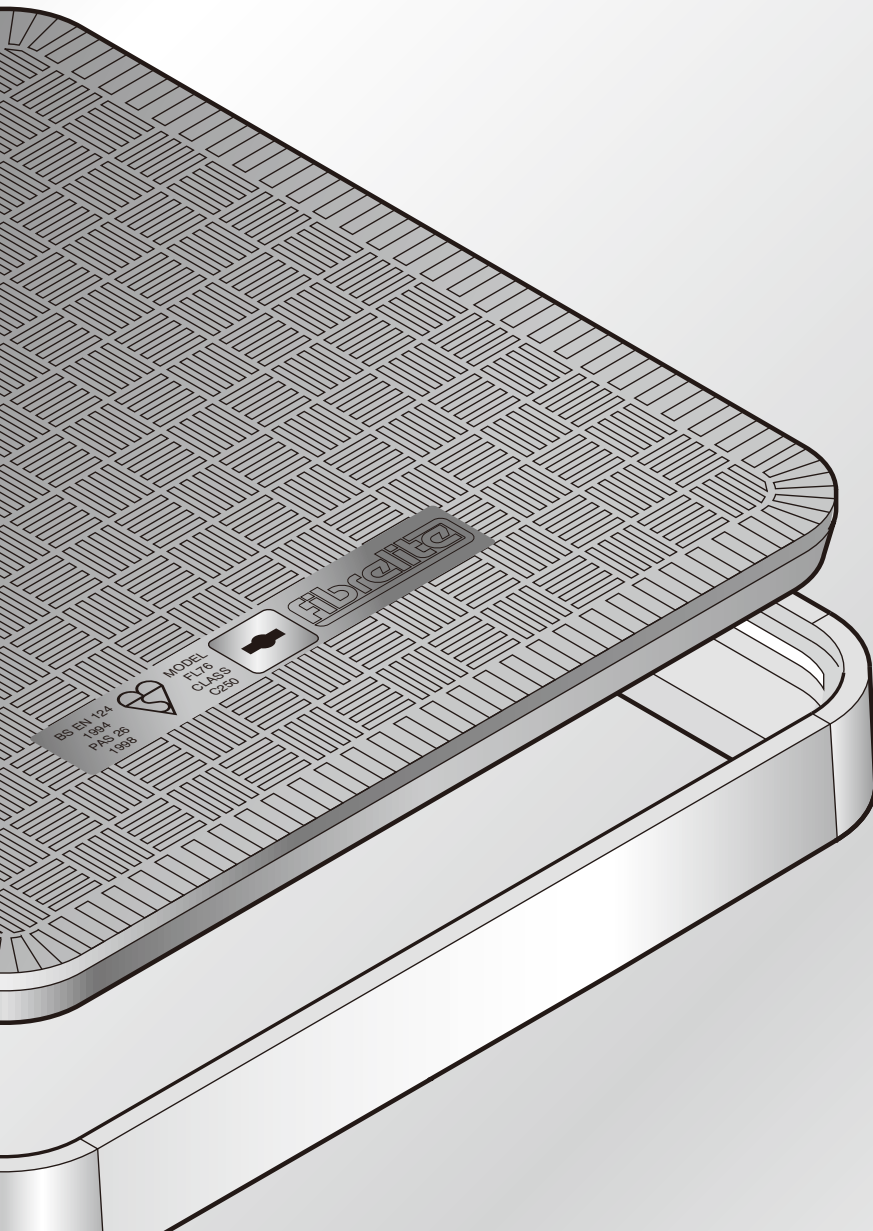

US Office:

100 Mechanic Street, Pawcatuck, CT 06379, USA
Tel: +1 860 599 6081, Fax: +1 860 599 1037, E-mail: covers@fibrelitecorp.com

UK Office:

Snaygill Industrial Estate, Keighley Road, Skipton, North Yorkshire, BD23 2QR, UK
Tel: +44 (0)1756 799773, Fax: +44 (0)1756 799539,
E-mail: covers@fibrelite.com, Website: www.fibrelite.com