

Service Station Hardware

7 1/2", 12", & 18" Manholes with Cast Iron Rings



These manholes have a proven track record of trouble-free operation. Their durable construction withstands the heaviest traffic and meets the requirements of a D.O.T. H20 load rating.

Design Highlights & Advantages:

- **Cast Iron Cover and Rings** - EBW's 7 1/2" round manholes have ribbed cast iron covers and cast iron rings to withstand heavy loads and traffic.
- **Colored Cover Options** - EBW's 18" round manholes can be ordered with optional FRC colored covers in standard API color codes. The FRC covers also include a recessed area for optional API color coded identification plates.
- **Heavy Duty Skirts** - EBW's 7 1/2" round manholes have heavy duty cast iron skirts. 12" and 18" round manholes have a 16 gauge welded steel skirt and are available in different depths to fit your needs.



18" MANHOLE



12" MANHOLE



7 1/2" MANHOLE

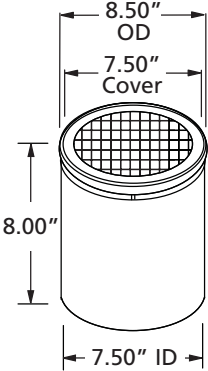
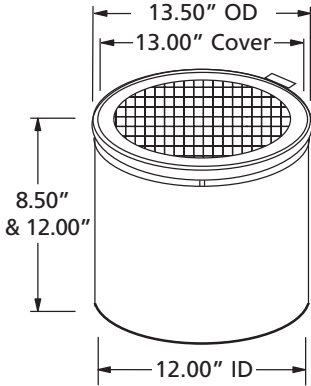
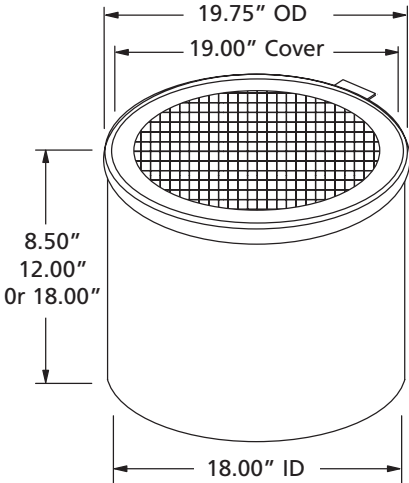



7 1/2", 12", & 18" Manholes

PART	MANHOLE SIZE		COVER TYPE	SKIRT DEPTH		LBS.	KG.
	IN.	MM.		IN.	MM.		
781-208-08	7.5	191	Cast Iron	8	203	22	10
781-212-12 -CI	12	305	Cast iron	12	305	36	16
781-212-12-CI-H	12	305	Cast iron with handle	12	305	36	16
781-212-24-CI	12	305	Cast iron	24	610	70	32
781-418-08 GRY	18	457	FRC	8.5	216	30	14
781-418-08 BLK	18	457	FRC	8.5	216	30	14
781-418-12 GRY	18	457	FRC	12	305	33	15
781-418-12 BLK	18	457	FRC	12	305	33	15
781-418-18 BLK	18	457	FRC	18	457	39	18
781-478-65	18	457	FRC	8.5	216	30	14

Replacement Covers

PART	IN.	MM.	COVER TYPE	LBS.	KG.
781-402-01	7.5	191	Cast iron	6	3
781-400-01	12	305	Cast iron	17	8
781-407-01	12	305	Cast iron with handle	18	8.1
781-302-01	12	305	FRC - black	10	5
781-302-07	12	305	FRC - orange	10	5
781-306-01	18	457	3/8" steel	33	15
781-304-01	18	457	FRC - black	10	5
SRC18HRP	18	457	Steel - bolt down	33	15

18" Monitoring Well Manhole with FRC Skirt PHIL-TITE

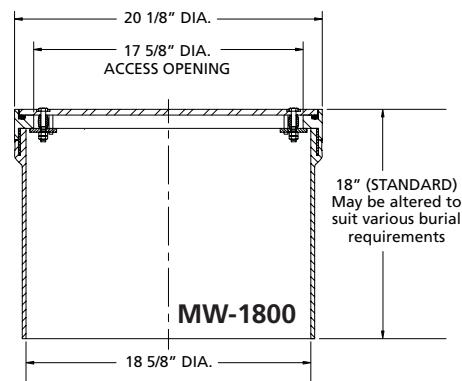

Design Highlights & Advantages:

- Patented watertight "D" profile O-ring seals cover and prevent groundwater intrusion.
- Gravel guard is 3/16" thick corrosion proof FRP.
- Covers use cam locks with stainless steel hardware eliminating corroded threads, lost bolts and water entry from not reinstalling bolts after service.
- Grey powder coated manhole cover.

MODEL	DESCRIPTION
MW-1800	18" Monitoring Well with FRC skirt