

# ***RX™ Quick Closures***



## **Product Description:**

Rhino Process Equipment provides **RX™ Quick Closures** to oil, gas and liquid service and operator companies. Rhino is capable of providing quick closures for any size and pressure ratings.

**STANDARD RHINO™ PIG LAUNCHER & PIG RECEIVERS** comes with the **STANDARD RHINO™ RX QUICK CLOSURE**.

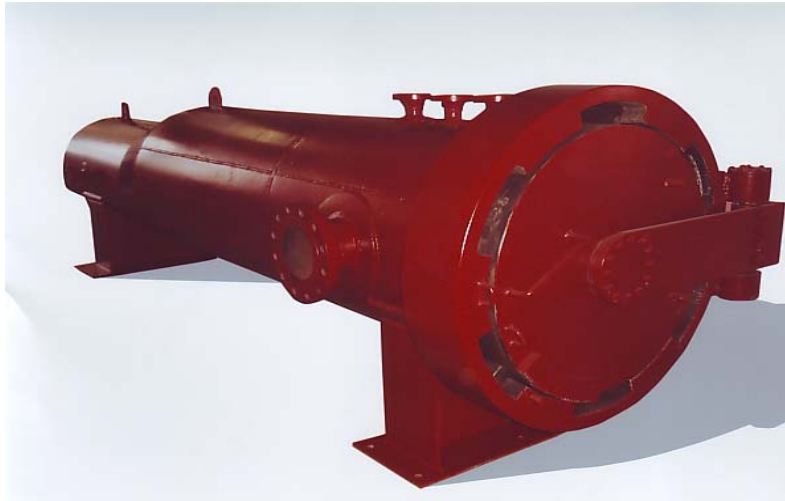
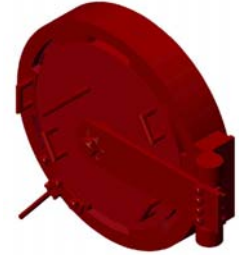

## **Product Benefits:**

- Easy to use and install, can be applied all kind of pressure vessels.
- You do not need a special tool or experience to install the closures

**Rhino™** quick closures is made of corrosion resistant materials with long life duration.+

## **Key Features:**

- Designed to ASME B31.4 , ASME B31.8 and ASME Section VIII Div. 1 Codes
- All **RX™ Quick Closures** comes with the sand blasted and primer coated and color of your choice.
- **RX™ Quick Closures** can be hydrostatically tested on request.
- **Rhino™** offers spare parts for all of its products during maintenance.
- Internal inspection and test certificates will be provided for each item.



*Made in Europe*

Rhino is registered trademark of Ergil Group

M.Nezih Ozmen Mah.Fatih Cad.Kayikci Sk.No.8 K:2 Merter-ISTANBUL -TURKEY

Phone: +90 212 643 62 26 (Pbx) Fax: +90 212 643 62 22

[www.pigreceiverlauncher.com](http://www.pigreceiverlauncher.com) [www.ergilgroup.com](http://www.ergilgroup.com) [info@ergilgroup.com](mailto:info@ergilgroup.com)

# RX™ Quick Closures



- Third party inspection can be provided TUV, Breu Veritas, or Lloyd if it is requested

## Dimensions and Weight:

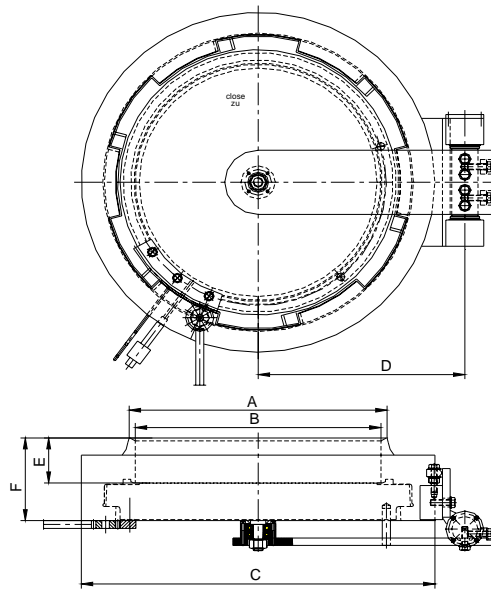

A Size In. (mm)	B Overall Inside Diameter In. (mm)	C Overall Outside Diameter In. (mm)	D Overall Length In. (mm)	E Height In. (mm)	F Height In. (mm)
10" (274)	10-1/4 (261)	14-3/4 (375)	8-2/3 (220)	1-3/9 (33)	2-9/10 (75)
12" (323.9)	11-1/2 (293)	19 (483)	11-1/9 (282)	2-3/9 (60)	7-2/7 (185)
14" (355.6)	13-1/7 (333,4)	19-3/5 (498)	11-3/5 (295)	2-9/10 (75)	6-1/10 (155)
16" (406.4)	15-1/3 (388,6)	22 (560)	12-9/10 (328)	2-9/10 (74)	6-7/10 (170)
18" (457)	17-1/5 (437)	24-3/4 (629)	12-9/10 (328)	2-9/11 (71,5)	5 (126)
20" (508)	19-1/8 (485,7)	27-1/2 (699)	16-1/10 (409)	3-1/7 (80)	5-1/5 (140)
30" (761.7)	29 (735)	39-3/8 (1000)	23-2/9 (590)	4-5/7 (120)	11-1/2 (292)
36" (914)	34-3/4 (882)	47-2/8 (1200)	28 (712)	2-9/10 (75)	9-1/4 (235)
40" (1016)	38-3/4 (984)	50-7/9 (1290)	29-5/6 (758)	3-1/8 (79,5)	9-6/7 (250)
44" (1117.4)	42-1/6 (1071)	60-5/8 (1540)	39-1/5 (996)	6-5/7 (170,5)	12-1/8 (308)
48"(1219.2)	42-2/6 (1169,2)	61-1/7 (1675)	35-3/4 (980)	8 - (204)	14-1/2 (368)



Made in Europe

Rhino is registered trademark of Ergil Group

M.Nezih Ozmen Mah.Fatih Cad.Kayikci Sk.No.8 K:2 Merter-ISTANBUL -TURKEY

Phone: +90 212 643 62 26 (Pbx) Fax: +90 212 643 62 22

[www.pigreceiverlaunher.com](http://www.pigreceiverlaunher.com) [www.ergilgroup.com](http://www.ergilgroup.com) [info@ergilgroup.com](mailto:info@ergilgroup.com)

# *RX™ Quick Closures*



## **Ordering**

### STANDARD RHINO™ RX QUICK CLOSURE

#### **Technical Closure Specifications**

Size Range:	6” to 52” Nominal
Class Rating:	ANSI 150, 300, 600, 900, 1500
Design Specification:	ASME VIII Division 1 ASME VIII Division 2 ANSI B31.3, B31.4, B31.8 Other international standards are available on request.
Closure Configurations:	Horizontal or Vertical.
Material of Construction:	ASTM A 350 LF2 / ASME II SA350 LF2 ASTM A 105/ ASME II SA 105 304L or 306L Stainless Steel and Duplex Stainless Steel
Sealing:	Elastomeric Lip Seal, Nitrile, Viton, Pur, Elast-O-Lion . Others on request.
Accessories:	Key Interlock System Pig indicator



*Made in Europe*

Rhino is registered trademark of Ergil Group

M.Nezih Ozmen Mah.Fatih Cad.Kayikci Sk.No.8 K:2 Merter-ISTANBUL -TURKEY

Phone: +90 212 643 62 26 (Pbx) Fax: +90 212 643 62 22

[www.pigreceiverlaunher.com](http://www.pigreceiverlaunher.com) [www.ergilgroup.com](http://www.ergilgroup.com) [info@ergilgroup.com](mailto:info@ergilgroup.com)

Doc. No: ERG-BRO-EMM-RHN-101-01- REV-A