

SPECIFICATIONS

700-35 Flow Meter

**TOTAL
CONTROL
SYSTEMS**



Total Control Systems rotary positive displacement flow meters offer reliable and precise measurement solutions for preset delivery, flow rate control, blending and custody transfer of vehicle or wholesale measurement applications.

INDUSTRIES SERVED

- Petroleum Products
- Alternative Fuels
- Aviation Fuels
- Agricultural Chemicals
- Petrochemicals
- Textiles
- Foods and Beverages
- Paints and Coatings
- Pharmaceuticals
- Printing Inks

DESIGN

The 700-35 flow meter has a simple and efficient meter design consisting of a housing and three rotors that rotate in unison within the measuring chamber. The absence of wear, from no metal-to-metal contact inside the chamber, eliminates any deterioration in accuracy and provides a long service life. The rotors are supported by bearings inserted into two bearing plates, where at the end of each rotor shaft is a timing gear. The timed rotation between each rotor is then transferred through the calibration adjuster to the register, which will then give a consistent and superior measurement of accuracy.



FLOW ILLUSTRATION

PERFORMANCE FEATURES

LOW PRESSURE DROP: will operate on gravity flow or pump pressure

SUSTAINED ACCURACY: no metal-to-metal contact inside the measuring chamber means minimal wear and deterioration in accuracy over time, fewer recalibrations and longer service life.

VISCOSITY RANGE: will accurately measure liquids up to 1,500,000 SSU (325,000 CPS)

LINEARITY:

5:1 Turndown - capable of $\pm 0.100\%$ of maximum nominal flow rate

10:1 Turndown - capable of $\pm 0.125\%$ of maximum nominal flow rate

15:1 Turndown - capable of $\pm 0.150\%$ of maximum nominal flow rate

REPEATABILITY: capable of 0.02% over the entire range of flow

Data provided from test conditions where all system variables were constant. The results are based on the 700 series flow meter and Veeder Root mechanical registration, using 32 SSU testing fluid.

REGULATORY: Meets NIST, USA military and other international weights and measures accuracy requirements.

OPERATING SPECIFICATIONS

DESIGN TYPE: Positive Displacement Rotary Abutment

FLOW CAPACITY: 20 GPM to 300 GPM
57 LPM to 1135 LPM

VISCOSITY: Up to 225 SSU at rated capacity.

PRESSURE RATING: 150 PSI
10.5 BAR

TEMPERATURE RATING: -40°F to 160°F
-40°C to 71°C

CONNECTIONS: 3" NPT Standard; Optional BSPT, Slip Weld, ANSI and DIN flanges are available upon request.

METER TYPES

SPA Standard Petroleum (Aviation)

For metering refined petroleum products; such as Regular and Unleaded Gasoline, Diesel, Bio-Diesel, Aviation Gasoline, Jet Fuel, Naptha, Kerosene, etc.

SPD Standard Petroleum (Ductile Iron)

For metering refined petroleum products; such as Ethanol, Methanol, Regular and Unleaded Gasoline, Diesel, Bio-Diesel, Natural Gasoline, Vegetable Oils, Kerosene, etc.

MATERIALS OF CONSTRUCTION

Meter Type	Housing	Rotors	Bearing Plates	Bearing Sleeves	Journals	Timing Gears	Internal Hardware	Seals
SPA	Anodized Aluminum	Anodized Aluminum	Ni-Resist	Carbon Graphite	Hardchrome Stainless Steel	Stainless Steel	Stainless Steel	Viton ®
SPD	Ductile Iron	Ni-Resist	Ni-Resist	Carbon Graphite	Hardchrome Stainless Steel	Stainless Steel	Stainless Steel	Teflon ® & Simriz ®

Viton is a registered trademark of E.I. Dupont de Nemours & Co.

Teflon is a registered trademark of Dupont Dow Elastomers

Simriz is a registered trademark of Freudenberg-NOK

REGISTRATION OPTIONS

COUNTER REGISTER

Liquid measurement volume indication, using a 5 digit large numeral reset display and an 8 digit non-reset totalizer. Electronic or mechanical meter counter register is available. U. S. or Imperial Gallons, Liters, Dekaliter, Barrels, pounds, etc.

COUNTER PRESET

Select predetermined volume for precise batch control, utilizing preset control valve. Mechanical or electronic preset counters or batch controllers are available.

TICKET PRINTER

Provides an imprinted ticket record of each delivery transaction. Accumulative or Zero-Start, Face down or Face Up mechanical ticket printers available. Electronic slip or roll printers available for use with various electronic registration.

ELECTRONIC METER REGISTER

Digital liquid measurement volume indication that offers multiple functions to enhance the flow meter's accuracy and accountability. Most electronic registration are available with rate of flow indication, pulse output, valve control, RS232 and RS485 communication, currency and temperature compensation.

PULSE TRANSMITTER

The electronic pulse signal output converts the register counter volume per unit value into a electrical pulse stream. The electronic pulse stream can be transmitted to other electronic controllers for rate of flow, volume indication, additive injection or data acquisition.

TEMPERATURE COMPENSATION

Automatically corrects changes in volume caused by liquid temperature variations, during metered delivery. Normally corrects net volume or mass to 60°F (15°C) based on the product's coefficient of expansion, API or specific gravity.

MICROSWITCH

Mechanical signal from the Veeder Root preset counter converted into an electrical or pneumatic signal to provide control of remotely located valve, pump, and other system related equipment.

COUNTER EXTENSION

Raises the elevation of the counter registration for easy visibility or to protect from high temperatures. Counter Extension is required for temperatures more than 180°C (82°C).

RATE OF FLOW INDICATOR

Mechanical or digital indicator displays the volume at which the liquid is flowing through the flow meter.

SWIVEL

Allows mechanical registration to be rotated 360°. Designed for the Veeder Root counter register and ticket printer only.

METER ACCESSORIES

AIR ELIMINATOR

A float and reed valve operated design senses and removes free air or vapor before it can enter the flow meter. Required for custody transfer applications to ensure the most precise measurement.



STRAINER

A 90° strainer provides protection from debris entering into the flow meter. Must be mounted in vertical position when assembled with air eliminator. Stainless steel screens are available in 40, 80, 100 & 200 mesh, and 0.050 perforation.



HIGH CAPACITY STRAINER

An offset 90° strainer and air eliminator assembly designed for use in applications where a high volume of free air may potentially enter the measurement system. Recommended for mobile fuel delivery systems to pass product depletion (split compartment) testing.



MECHANICAL PRESET VALVE

A normally closed, hydraulically balanced piston control valve allows for auto-batch preset deliveries. The right angle, two-stage control valve is mechanically linked to Veeder Root Preset Counter.



ELECTRONIC PRESET VALVE

A normally closed two-stage piston preset valve for use with electronic relay control. The solenoid valves are available in 12 or 24 VDC, or 110 VAC coils. Stainless steel or brass pilot valves are also available. Dimensionally interchangeable with the mechanical valve.



PNEUMATIC PRESET VALVE

Air actuated, normally closed two-stage piston preset valve for use in systems with air supply. Dimensionally interchangeable with the mechanical valve.



AIR CHECK VALVE

The spring loaded check valve provides 15 PSI differential pressure to increase air eliminator efficiency and to prevent metering compressed air produced by a positive displacement pump during a stripping operation of the vessel being emptied.



WAFER CHECK VALVE

In-line check valve is mounted between the strainer and meter assembly to help increase air eliminator efficiency by creating additional back pressure.



ASSEMBLY COMBINATIONS

GROUP COMBINATIONS

- 2 Meter & Register
- 3 Meter, Register & Ticket Printer
- 4 Meter, Register, Air Eliminator & Strainer
- 4R Meter, Register, Air Eliminator & High Volume Strainer
- 5 Meter, Register & Strainer
- 6 Meter, Register, Ticket Printer, Air Eliminator & Strainer
- 6R Meter, Register, Ticket Printer, Air Eliminator & High Volume Strainer
- 7 Meter, Register, Printer, & Strainer
- 8 Meter, Register, Preset & Valve
- 9 Meter, Register, Ticket Printer, Preset & Valve
- 10 Meter, Register, Preset, Valve, Air Eliminator & Strainer
- 10R Meter, Register, Preset, Valve, Air Eliminator & High Volume Strainer
- 11 Meter, Register, Ticket Printer, Preset, Valve, Air Eliminator & Strainer
- 11R Meter, Register, Ticket Printer, Preset, Valve, Air Eliminator & High Volume Strainer
- 12 Meter, Register, Preset, Valve & Strainer
- 13 Meter, Register, Ticket Printer, Preset, Valve & Strainer

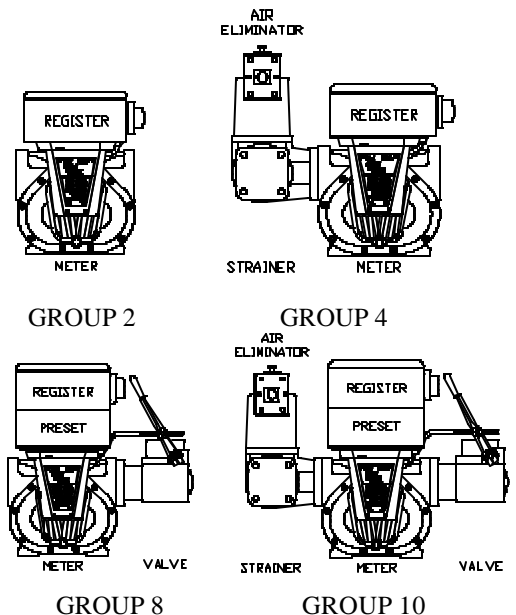

METER ORIENTATION

- A Meter Assembly with Veeder Root Registration
- B Meter assembly less Veeder Root Registration
- C Meter Assembly for use with Electronic Registration (less calibration adjuster)
- D Meter Assembly with direct drive pulse transmitter



700-35 DIMENSIONS

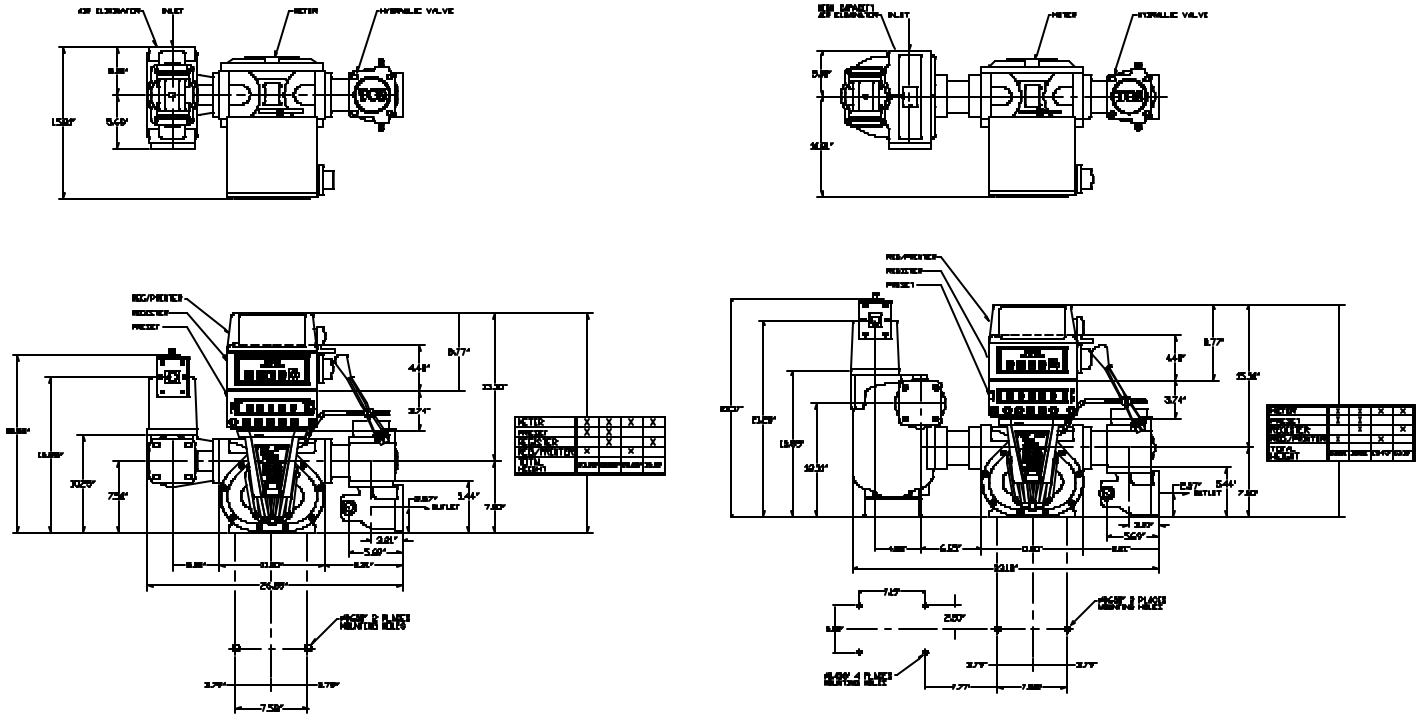

700-35 NET WEIGHTS IN POUNDS (KILOGRAMS)

Meter Type	Flow Meter	Register Counter	Preset Counter	Ticket Printer	Air Eliminator/ Strainer	Air Eliminator /High Volume Strainer	Strainer	Electronic Valve	Mechanical Valve	Air Check Valve
SPA	53 (24.0)	12 (5.4)	10 (4.5)	12 (5.4)	20 (9.1)	37 (16.8)	13 (5.9)	17 (7.7)	12 (5.4)	12 (5.4)
SPD	125 (56.7)	12 5.4	10 4.5	12 5.4	59 (26.8)	N/A	38 (17.2)	34 (15.4)	N/A	N/A

WARRANTY

Total Control Systems 700 rotary meters and accessory components sold to the original purchaser for a period of TWELVE (12) months from installation or EIGHTEEN (18) months from the date of shipment, to be free, under normal use and service, from defects in material and workmanship. If a warranty dispute occurs the DISTRIBUTOR may be required to provide proof of date of sale. Defects occurring within the stated warranty period, will be repaired or replaced, at TCS's option; provided that part or parts are returned to TCS transportation changes prepaid, and TCS's examination discloses the parts or workmanship to have been defective upon delivery to the purchaser. All repaired or warranted meters will be shipped Ex-works Fort Wayne, Indiana. Total Control Systems shall not be liable for consequential damages, whether or not arising out of warranty, negligence or otherwise.

NOTE: The above warranty applies only to Total Control Systems, Fort Wayne, Indiana manufactured products. Private label and OEM engineered products are specifically excluded from the above warranty. Consult factory for non-TCS manufacturer's warranty.



TOTAL CONTROL SYSTEMS
 2515 Charleston Place
 Fort Wayne, Indiana 46808 USA
 (800) 348-4753 • (260) 484-0382
 Fax: (260) 484-9230
 sales@tcsmeters.com • www.tcsmeters.com



"Made in the U.S.A."