

Tightness Control System (TCS)

Technical Description

1. History

The Tightness Control System TCS has been developed by Hansa Consult Ingenieurgesellschaft mbH together with Fraunhofer Gesellschaft and Krupp-Atlas in 1982, originally for operation at Frankfurt Airport (FRA). The system is based on the so-called Pressure Step (PS) method, which offers quite short test periods compared to other systems.

Since 1982 TCS has been installed more than forty times all over the world and has proven its accurate function.

2. Introduction

Tightness control on facilities for transportation or storage of waterpolluting liquids is a preventive action which is becoming more and more important.

Besides economic reasons for leakage control, safety and environmental aspects are playing a considerable role. Leakages which have not been detected in time can cause environmental damages, which are costly to restore. Furthermore the reputation and public image of the

company can suffer severely as a consequence of such damage.

Due to this reason leakage control is legally required in Germany for buried pipelines which transport water polluting liquids.

Various methods exist to control tightness of buried pipelines. The most important and generally accepted methods are:

- Pressure-Step Method
- Pressure-Temperature Method
- Volume-Comparison Method
- Pressure-Differential Method for comparable pipeline sections

The detection of small leakages and their long-term danger potential is only achievable with the Pressure-Step method or the Pressure-Temperature method.

3. Measurement Method for Buried Pipeline Systems

3.1. The Pressure-Step (PS) Method

The idea of this method is to pressurize a pipeline section successively with two different test pressures. The pressure of the medium is measured, but not its temperature.

It is of course required that the individual pipeline sections are absolutely tightly closed.

This method is based on the physical fact that - in case of a leak - at high pressure the product leakage is higher than at low pressure. The method is able to detect leakages with an accuracy of

0.04 litre / h / m³

or

0.0003 gallons / h / ft³



Main hydrant pipes disappearing into the ground

Tightness Control System (TCS)

Principle of Pressure-Step-Method

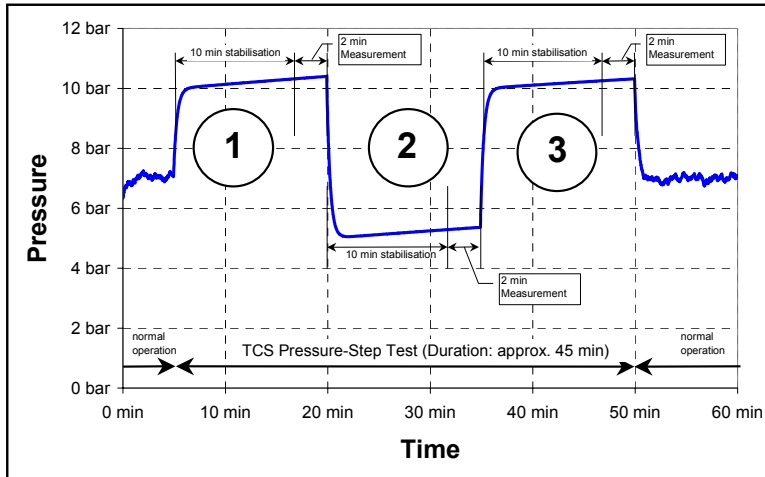

This has been certified by

- TÜV Technology Certification, Feb. 1994
- Institute of Petroleum, LD Protocol, 1994
- US EPA Third Party Certification – Ken Wilcox Associates, August 2000
- State of Florida, Technology Approval, September 2000

The minimum absolute amount of detectable leaking liquid depends on the volume of the tested pipeline section.

The PS-method is especially suitable for installation in existing pipeline systems. The cost for such an installation is particularly low compared to other methods. In addition to this, the PS-method offers a short test cycle of only approx. 45 min.

3.2. The Pressure-Temperature (PT) Method

This method measures pressure and temperature in a pipeline section over a long period of time (up to several days). In a tightly closed pipeline section a physical relation exists between the temperature gradient and the pressure gradient of the medium. A pressure variation caused by leakages can be detected by comparison with the temperature variation. The accuracy is up to a detectable 4 l/h leakage rate, depending on the test time, but it does not depend on the size of the pipeline section. This method requires the ability to close the individual pipeline sections absolutely tight, too.

While testing the section the temperature must also be measured in addition to the pressure. The advantage of the

PT-method is the relatively high measurement accuracy. The disadvantage of this method is the fact that it is absolutely necessary to measure the temperature. The installation of a temperature transmitter into an existing underground pipeline system is only possible with substantial effort. In addition, on long pipelines more than one temperature probes are needed. Finally, the required test period is significantly longer than with the PS-method, so that for example daily tests are not possible.

3.3. Volume-Comparison Method

Pipelines are controlled by flow meters in order to execute a volume comparison. A leak is detected if a volume loss is indicated between the pump station and the receiver.

This method is normally used to control running pipeline systems. Due to large measurement tolerances only large leakage rates are detectable.

3.4. Pressure-Differential Method for Comparable Pipeline Sections

This method is based on the pressure variation within non-operating sections. The accuracy of this procedure depends on the comparability of the environmental factors. Only quite significant leakages can be detected with this method.

4. Tightness Control for Hydrant Systems

4.1. Hydrant Systems

Hydrant systems are used on various airports to supply airplanes with the required fuel. Hydrant systems are buried pipeline systems which transport fuel from storage tanks to airplanes.

The fuel is transported from the storage tanks into the hydrant system by pumps. It is taken from the hydrant system at special points (pits), where the fuel is delivered to the airplane with reduced pressure via special dispensers (servicer).

Depending on the individual requirements of the hydrant system, the respective pipeline system can be split up into various sections. Therefore only the Pressure-Step method or the Pressure-Temperature method are able to guarantee adequate leakage control of a hydrant system.

4.2. Pressure-Step Method for Hydrant Systems

The Tightness Control System (TCS) of Hansa Consult is based on the PS-method. It is especially designed for installation into

Manual and Motor Operated Valves



Tightness Control System (TCS)

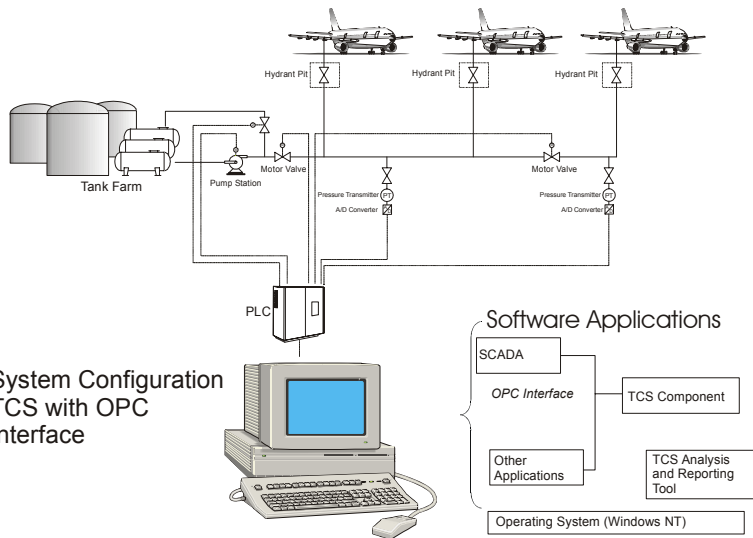

System Configuration
TCS with OPC
Interface

existing hydrant systems. This is possible without great efforts. Due to the short test time of the Pressure-Step (PS) method (approx. 45 min.), TCS is able to prove actively the tightness of the hydrant system daily. This ensures highest safety for the operating company.

Furthermore, TCS can run the test fully automatically during non-operating periods.

For tightness control by TCS the hydrant system is separated into single, absolutely tight sections. These sections are controlled simultaneously during the test. The size of the sections defines the absolute accuracy of the test.

Hansa Consult guarantees the ability of TCS to detect leakages of 0.04 liters per hour and cubic meter of enclosed volume.

In special cases, e.g. air enclosures in the hydrant system (surge suppressor for absorbing of pressure peaks), the detection accuracy will change, depending on the volume of these enclosures.

4.3. Pressure-Temperature Method for Hydrant Systems

The operation of hydrant systems at busy airports can be interrupted for tightness control only for short periods of time. When using the PT method for daily tightness control the pipelines have to be equipped with a large number of temperature probes in order to achieved test periods.

The pipelines of a hydrant system are installed mainly under a concrete base of up to 60 cm. The retrofit of temperature probes in such areas is almost impossible.

Therefore the PT method is recommend for yearly test at a

high absolute accuracy only. For daily tests the PS method is recommend.

Hansa Consult's TCS can offer both methods if requested by the customer.

5. Requirements for Installation

The following requirements are necessary for the installation of TCS:

- The pipeline sections to be tested shall be closed by absolutely tight valves (e.g. Double-Block-and-Bleed-Valves), in order to avoid leak alarms caused by leaking valves.
- Air enclosure have to be eliminated by regular ventilation. If this is not possible the detection accuracy will be decreased.

6. TCS Equipment

For the installation of TCS the following facilities are necessary:

- Pressure transmitters (for each pipeline section one pressure transmitter is required)
- Data transmitting system for the data transmission to the computer.
- Means for Pressurization / Depressurization of the system to create the test pressures in the pipeline sections
- SCADA system for automatic control of the hydrant system. For easy communication with TCS it is recommended that the SCADA system provides an OPC (OLE for Process Control) interface.
- Computer and peripheral equipment for evaluation and documentation of test results.

7. Test Procedure

The tightness control of the pipeline can be carried out daily by TCS. A "tightness factor" is determined by the evaluation of the measurement results. The tightness factor is the leaking liquid volume in liters per hour relative to the checked volume.

The tightness control is performed in 3 steps:

Phase 1: The pressure of the hydrant system is raised to the high pressure test level by the

Pressure and Temperature Transmitter on pipe



Tightness Control System (TCS)

Evaluation of Pressure-Step-Method

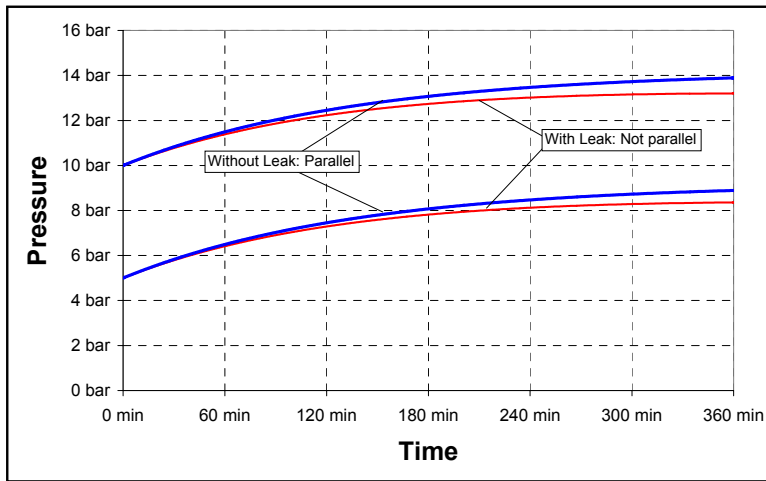

main pump or a jockey pump. The sections are closed absolutely tight after having reached this pressure. The measured pressure values are recorded by TCS over a period of two minutes after a stabilisation time of approx. 10 minutes.

Phase 2: The pressure in the hydrant system is reduced to a low pressure level by opening a pressure relief valve. The pressure relief valve is closed after reaching the desired test pressure and the system is stabilised for approx. 10 min. After the settlement TCS will again record and transmit pressure values over a period of two minutes.

Phase 3: Same procedure as in phase 1.

Between the individual phases the separation valves between the various sections are opened in order to establish a common pressure.

After having carried out the three phases of the test, the TCS evaluates the test data, calculates

the tightness factor and displays the condition of the hydrant system. If the tightness factor is not higher than the upper limit of $0.04 \text{ l}/(\text{h}\cdot\text{m}^3)$ the condition of the system is indicated as tight. A condition report is printed for documentation purposes.

A tightness control test with all 3 phases requires approx. 45 min. All sections of a hydrant system can be tested at once. After that period, the pipelines can be used for normal operation again.

8. Evaluation of Test Results

The test results enable TCS to compare the three pressure curves and to determine the tightness factor.

Assuming ideal conditions the curves would be horizontal and parallel. However, the effects of temperature result in parallel ascending or descending characteristics. Since the temperature gradient during the

test can be assumed to be linear, the temperature does not need to be measured and the temperature effects can be compensated. If the system is not tight the leakage will be higher at the high test pressure than at the low test pressure. As a result the pressure curves do not run parallel any longer.

The TCS software is able to determine the leakage rate on the basis of the specific properties of the material and geometry of the piping system. A leak can be detected after four consecutive measurements with a probability of 99 %. The evaluated tightness factors are recorded in a database. From this database statistics can be extracted in order to inform the user about variations of the conditions of the pipeline system .

The reliability of TCS can be demonstrated anytime by applying simulated leakages.

9. Summary

The Tightness Control System presented by Hansa Consult is a system which can actively control the tightness of a pipeline system at any time.

The measurement accuracy is 0.04 liters per hour and cubic meter of enclosed volume.

The measurement period required for a tightness control test is approx. 45 min.

TCS is especially suitable for installation in existing pipeline systems. Temperature measurement is not required.

The system has been installed more than 40 times all over the world and has proved its ability to detect actively smallest leakages within shortest time.

High Accuracy 22 Bit A/D Converters used for TCS

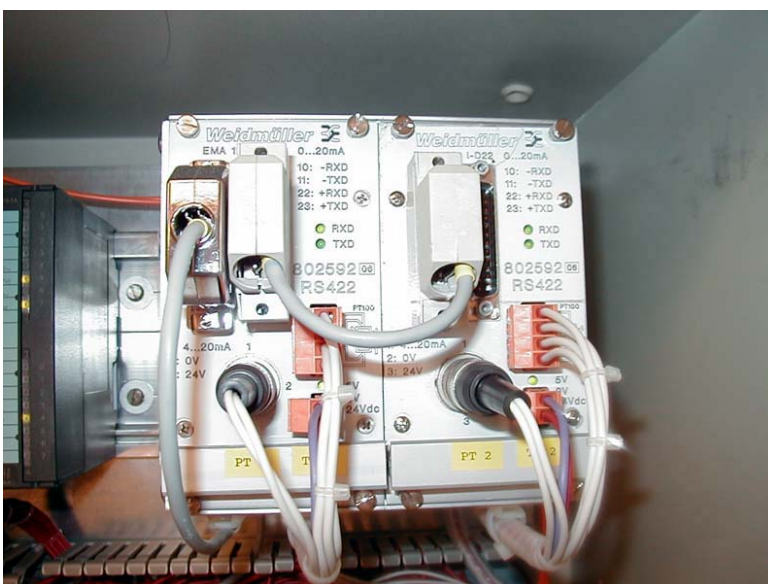

hc
hansaconsult
Ingenieurgesellschaft mbH

Beim Zeugamt 6
D-21509 Glinde
Germany
Tel.: +49 40 710 918 0
Fax: +49 40 710 918 30
Email: hc@hansaconsult.com
Web: www.hansaconsult.com