

Pow-R-Seal[®] API 6D Gate Valves



TABLE OF CONTENTS

WKM Pow-R-Seal GATE VALVES

Design _____	2 & 3
Operating Principles _____	4 & 5
Features _____	6, 7 & 8

DIMENSIONAL DATA

Model M	
2 in. - 4 in. (50 mm - 100 mm) _____	9
Model E1C	
6 in. - 12 in. (150 mm - 300 mm) _____	10
Model E1C	
14 in. - 24 in. (350 mm - 600 mm) _____	11

GEAR SIZING

Model M	
2 in. - 4 in. (50 mm - 100 mm)	
Model E1C	
6 in. -24 in. (150 mm - 300 mm) _____	12
Topworks Data _____	13 & 14
Flow Coefficients (C_v) _____	15
Flow Coefficients (K_v) _____	16
Partial Open Flow Characteristics (C_v or K_v) _____	17
Pressure Temperature Ratings _____	18 & 19
Trim Chart _____	20 & 21
Applications (Pictures) _____	22 & 23
TRADEMARK INFORMATION _____	24
TERMS AND CONDITIONS OF SALE _____	25

WKM POW-R-SEAL API 6D THROUGH-CONDUIT GATE VALVES

The WKM Pow-R-Seal valve's through-conduit design provides these specific advantages resulting in reliable performance and long life:

- Protection of seat faces. Seat faces are outside the flow stream and in full contact with the gate, in both fully open and fully closed positions. Seat life is thus greatly extended.
- Smooth, continuous conduit for flow. Destructive turbulence is eliminated. In a full-bore valve, pressure drop through the valve is no greater than that through an equal length of equal-diameter pipe.
- Block and bleed capability. The Pow-R-Seal valve in closed position forms a tight mechanical seal on both seats simultaneously, which allows the body cavity to be bled.

For specific applications, please consult factory.

TIGHT MECHANICAL SEAL

The Pow-R-Seal's parallel expanding gate design provides a tight mechanical seal, upstream and downstream simultaneously, which is normally unaffected by pressure variations or vibration. (See Operation, following page.) In the valve illustrated, for service at temperatures from -20°F to +300°F (-29°C to +148°C), the seal is both TFE-to-metal and metal-to-metal.*

*For service at high temperature, see pages 8-9.

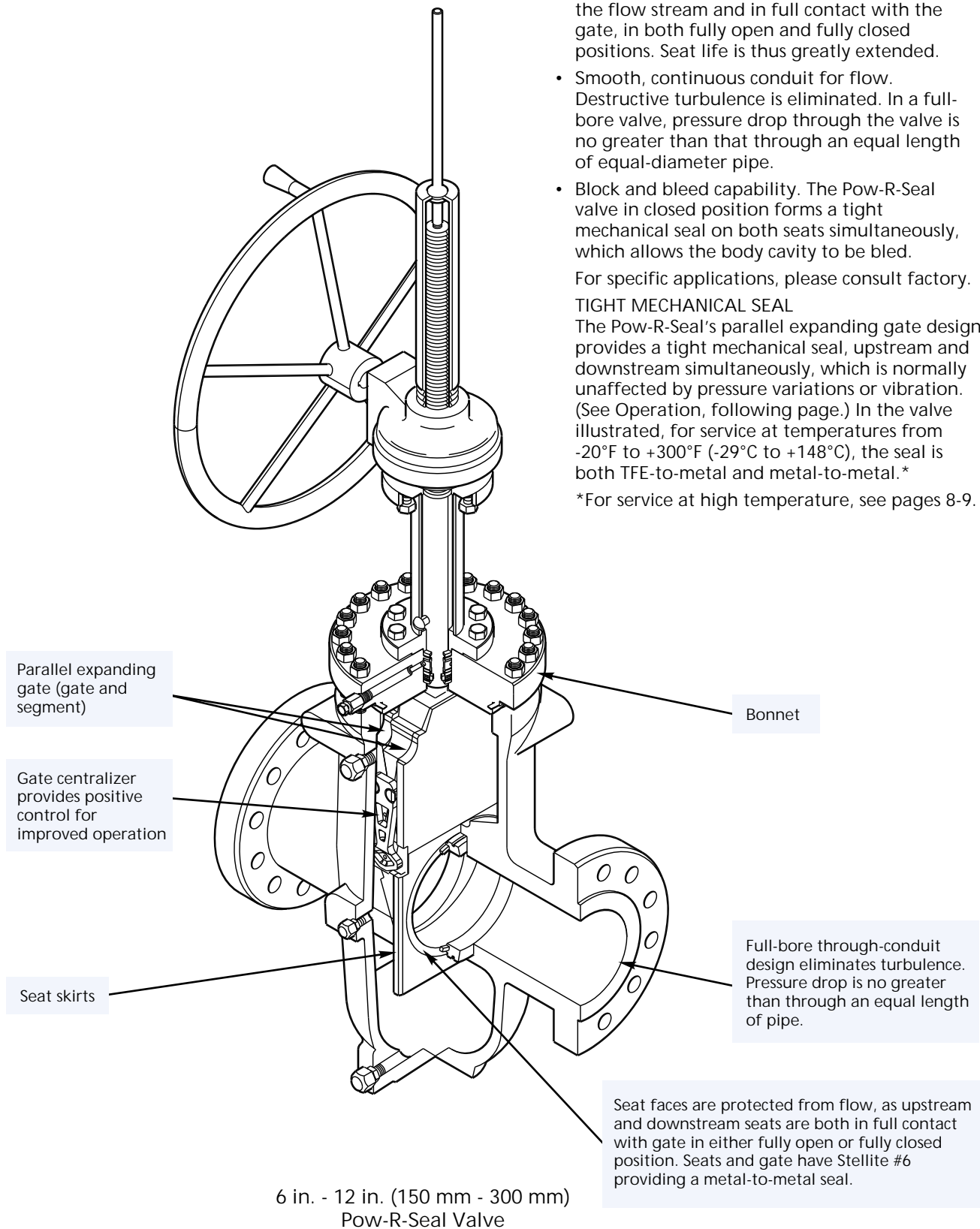

WKM POW-R-SEAL API 6D THROUGH-CONDUIT GATE VALVES

Pow-R-Seal valve for High-Temperature service Up to 1000°F (538°C)

This Pow-R-Seal valve can handle fluids, gases, steam and hot water at temperatures up to 1000°F (538°C). The valve has the following features which put it in a class by itself for such critical service:

- Metal-to-metal, mechanical seal - no elastomers. Valve does not depend on line pressure to shut off. Seal is normally unaffected by pressure surges, vibration, or heat.
- Adjustable outside packing gland - proved best for extremely hot service.
- Metal-to-metal bonnet seal - the bolted bonnet design used on 6 inch and larger valves and bolted bonnet design used on 4 inch and smaller valves provide metal-to-metal, tight bonnet seals in high temperature applications.
- Protected seat faces, a function of the valve's through-conduit design. Seat faces are outside the flow stream and in full contact with the gate, whether the valve is open or closed. Seats last longer and shut off tight.
- Smooth, continuous conduit for flow. No turbulence. In full bore valves, pressure drop is no greater than through an equal length of equal diameter pipe.
- Rising stem design - puts stem threads outside the critical heat area.

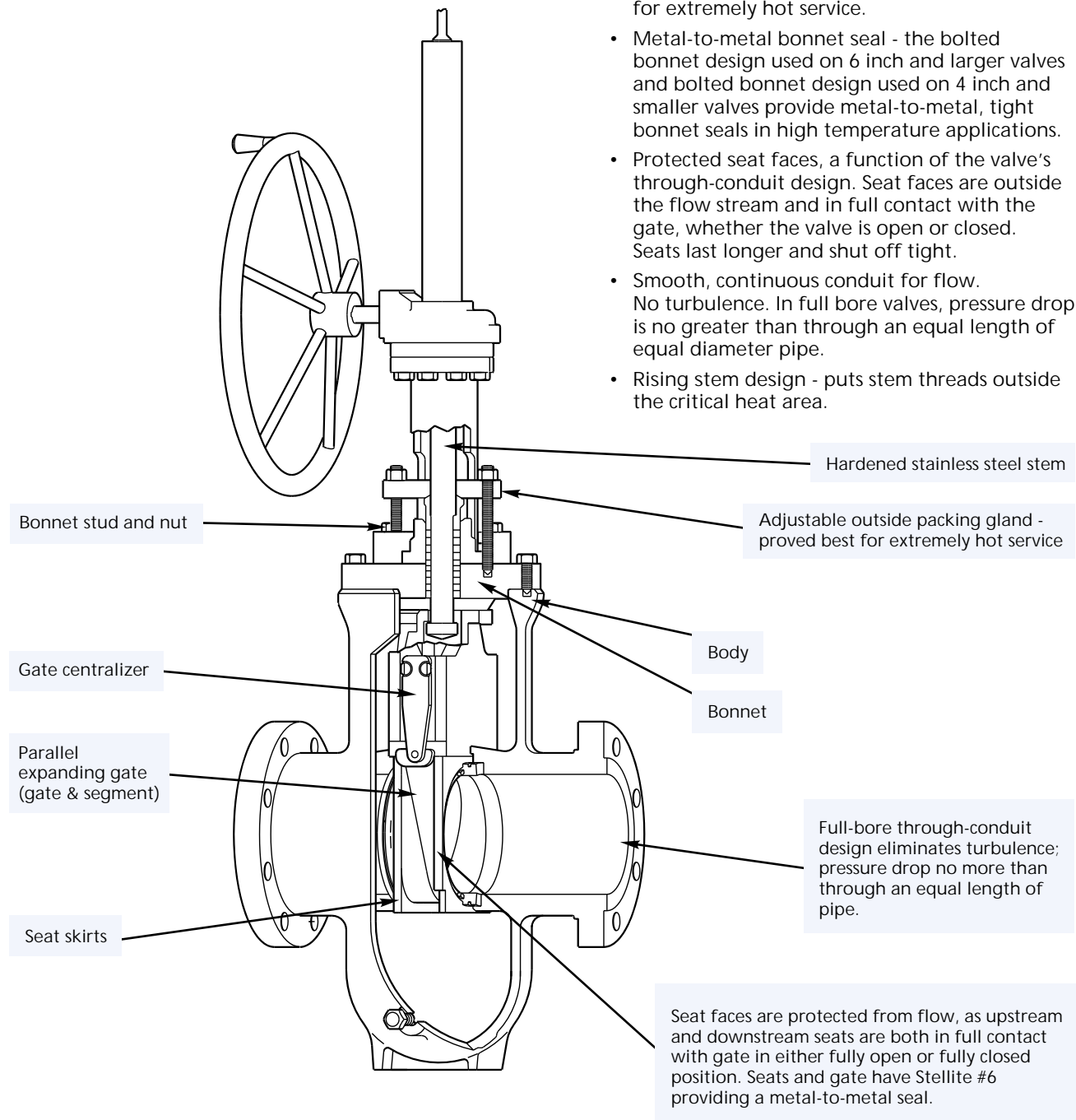

WKM POW-R-SEAL API 6D THROUGH-CONDUIT GATE VALVES

OPERATING PRINCIPLES

The Pow-R-Seal gate valve is a premium through conduit expanding gate valve. The parallel expanding gate design provides a tight mechanical seal which is normally unaffected by pressure variations. Each seat contains a plastic face seal. The seats are press fit into the body to affect a metal-to-metal body-seat seal. A non-metallic seat rear seal is also provided. All metal seats are available for special trims.

The full bore design has the same pressure drop as an equivalent length of pipe and allows passage of all types of scrapers (pigs).

The body center section is cast as a single piece to provide the necessary strength to resist pipeline bending moments.

The gate-segment assembly consists of Gate, Segment and Gate centralizer (two assemblies). The Gate-segment assembly is smaller than the space between the seats allowing free movement in the mid-travel position.

In the CLOSED position, the segment stops moving when it contacts the stop. Continued stem movement causes the gate to slide down the top angles, expanding the gate-segment outward against both seats. In the OPEN position, the segment stops moving when it contacts the stop.

Continued stem movement causes the gate to slide up the bottom angles, again expanding the gate-segment against both seats. Flow is isolated from the valve body. The gate centralizer allows the gate-segment to move freely and wedge only in the full open or full closed position.

Pow-R-Seal valves do not depend on lubrication for a seal in normal operation. However, lubricants/sealants can be injected to promote smooth operation*. Seat sealants can also be injected to affect a seal in an emergency should the seats become damaged due to foreign matter.

The stem is sealed by the SLS system. This seal is hydrocarbon fugitive emissions tested and has demonstrated seal-ability not to exceed 500 ppm leakage. It consists of a single Spring Loaded Lip seal, a lantern ring, a chevron ring and appropriate adapters. The Single

* Some high temperature valves do not have the seat injection feature.

Spring Loaded Lip seal contains four (4) separated sealing bands to promote reliability. The stem seal is completely contained in the bonnet. The stem is centered by bushings and the lower pedestal acts as a stem scraper. The seal works without a plastic injectable. In an emergency, plastic packing can be injected into the packing box to affect a temporary seal while the valve is under pressure.

The bonnet seal is made by a flat metal gasket in the 6 in. - 12 in. (150 mm - 300 mm) size range. Bonnet seals for sizes 14 in. - 24 in. (350 mm - 600 mm) are made with an O-ring seal. High temperature valves use a spiral wound metal gasket with a non-asbestos filler.

Pow-R-Seal valves are repairable in-line.

Pow-R-Seal gate valves meet the requirements of API 6D.

The valve stroke is established by manufacturing tolerances and cannot get out of adjustment.

Pow-R-Seal gate valves are available with hand wheel operators (some sizes), bevel gear operators, or less gearing (bare stem). Electric motor operators from a variety of suppliers can be offered.

Operator mounting is simplified as yoke tube upper flanges are in compliance with MSS-SP-102. Yoke tube flanges in compliance with ISO 5210 are available.

Pow-R-Seal gate valves are supplied with indicators as a standard for Handwheel and Bevel Gear Operated valves. Handwheel Operated valves have marks on the indicator rods which show when the valve is in the full open or closed position.

Pow-R-Seal gate valves are available with Lubrication/Packing/Drain extensions.

Pow-R-Seal gate valves are also available with Stem/Yoke tube extensions.

Pow-R-Seal gate valves are available with a variety of coatings including Coal Tar Epoxy for buried service, 2-3 part coating systems for marine environments, Inorganic Zinc Rich Epoxy, etc.

WKM POW-R-SEAL API 6D THROUGH-CONDUIT GATE VALVES OPERATION

WKM Pow-R-Seal is the ultimate choice for Full Port, Through Conduit, Positive Shut-Off gate valves.

60 years of Worldwide service in oil, gas, chemicals, water, slurry and multi-products has confirmed the Pow-R-Seal as the most trusted gate valve, where safety and reliability of sealing are critical.

The parallel expanding gate design provides a tight mechanical seal which is normally unaffected by vibrations or pressure variations.

The rigid, cast steel body resists pipeline bending moments, which could affect seat sealing in other valves.

PTFE seals on both faces of the valve assure drop tight sealing, while metal-metal contact between the seals and gate mechanism provides tight shut-off.

All-metal seals are also available for service to 1000°F (538°C), where leakage rates comply with API 6D/ISO 5208.

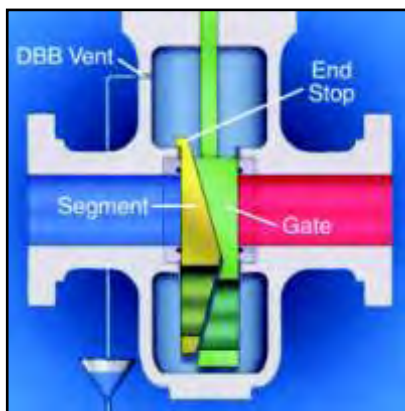

SEALED CLOSED

In the fully closed position the segment has engaged with an end-stop and the gate is wedged downward, expanding the segment and gate so that they form a tight mechanical closure against the upstream and downstream seats. Venting the body cavity will provide total, tight shut off.

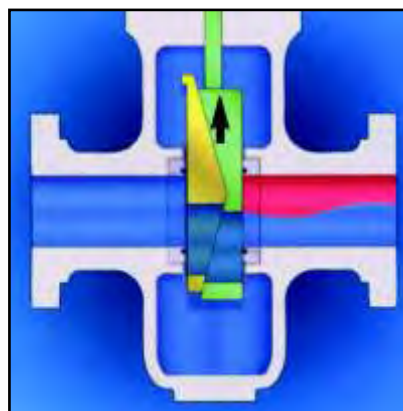

MID-TRAVEL

During travel towards Open, the gate slides across the wedge angle of the segment, collapsing the assembly so that it travels freely between the seal faces. The patented Leverlock gate centralizer holds the mechanism in the neutral position until seal expansion is required.

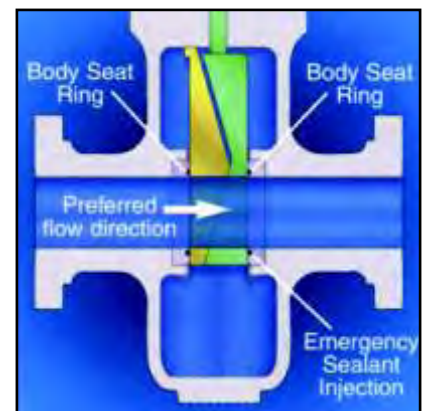

FULLY OPEN

When the bore in the segment is aligned with the conduit bore, an end-stop prevents further travel and the gate slides across the wedge angle, expanding the gate and the segment, isolating the flow from the body. The preferred flow direction assures easier operation.

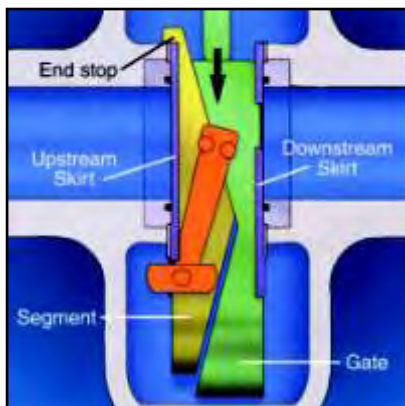

LEVERLOCK MECHANISM

The lever arm is held parallel to the gate faces by the skirt plates, while the assembly is moving through its stroke.

Near end-of-travel, the skirt allows the lever to tilt.

The gate and segment slide against their angled faces, creating the expanding seal action.

In their final position, the gate and segment are mechanically secured in place.

The skirt plates are guide rails, at the sides of the gate.

The skirts align the gate and segments with the seats.

WKM POW-R-SEAL API 6D THROUGH-CONDUIT GATE VALVES

FEATURES

Through-conduit design:
smooth bore, minimum pressure drop, protected seat faces

The Pow-R-Seal valve's smooth, continuous bore minimizes turbulence. In full bore valves pressure drop is no more than through an equal length of the same size pipe. Seat faces are outside the flow stream and thus protected from contact with the lading whether the valve is open or closed. The Pow-R-Seal's full round bore makes it possible to run pigs, scrapers or hot tap cutters through the valves without danger of damaging the valve, lodging the scraper, or jamming it with metal cutting.

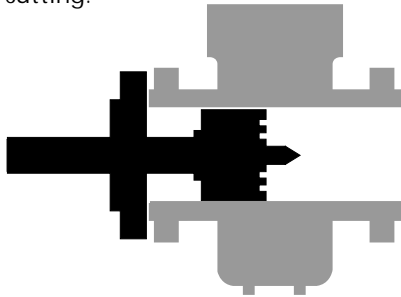

On-Line Overhaul

Pow-R-Seal valves can be overhauled right on the line. Gate, seats and other internal parts can be removed and replaced by a trained serviceman without excessive shutdown time.



Double-Sealing Replaceable Seats

Seats can be removed and replaced while the valve is in the line. Seats are provided with PTFE inserts and thus affect a double seal - an initial TFE-to-metal seal in addition to a metal-to-metal seal - both upstream and downstream. This feature does not apply to high temperature valves.

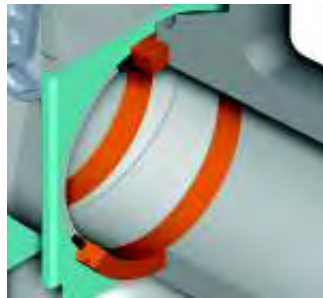

Gate and Segment/Stems

Pow-R-Seal gates and stems are Nickel Plated. HF-6 overlay is available on request for the gate/segment and seat sealing surfaces.



Gate Centralizer

Pow-R-Seals of 6 inch and larger sizes feature the leverlock® gate centralizer which retains the gate-segment assembly in a neutral position during opening and closing travel but permits expansion of the assembly at the proper moment for seating, in open or closed position.



Extensions

For valves which are to be buried, operated from a catwalk, or otherwise difficult to reach, stem and body fitting extensions can be supplied in virtually any desired length in 6 inch increments from the minimum extension length that can be furnished. Extensions come as original equipment or can be field-installed on valves already in service.

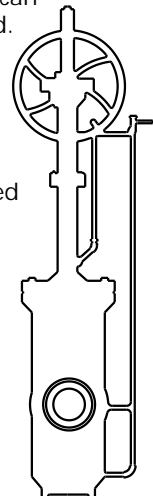

WKM POW-R-SEAL API 6D THROUGH-CONDUIT GATE VALVES

THERMAL RELIEF SYSTEM

Operations:

Because of the split gate design, it is possible for excess body pressure to develop in the body cavities of closed valves. This usually results from heating in the valves in liquid service. A thermal body cavity relief system is provided to relieve this excess body pressure. Thermal relief systems which direct excess body pressure to the upstream conduit are standard. This system consists of two (2) needle valves, a check valve, tubing and two (2) fittings.

Body pressure greater than the segment conduit pressure causes the check valve to unseat and relieve excess pressure to the upstream conduit. The needle valve must be kept open while the valve is in service. These needle valves can be used to isolate the line pressure to service the relief system, as needed. This illustrates the standard body relief system. Custom body relief systems may be available at extra cost.

TYPICAL THERMAL BODY CAVITY RELIEF ARRANGEMENT

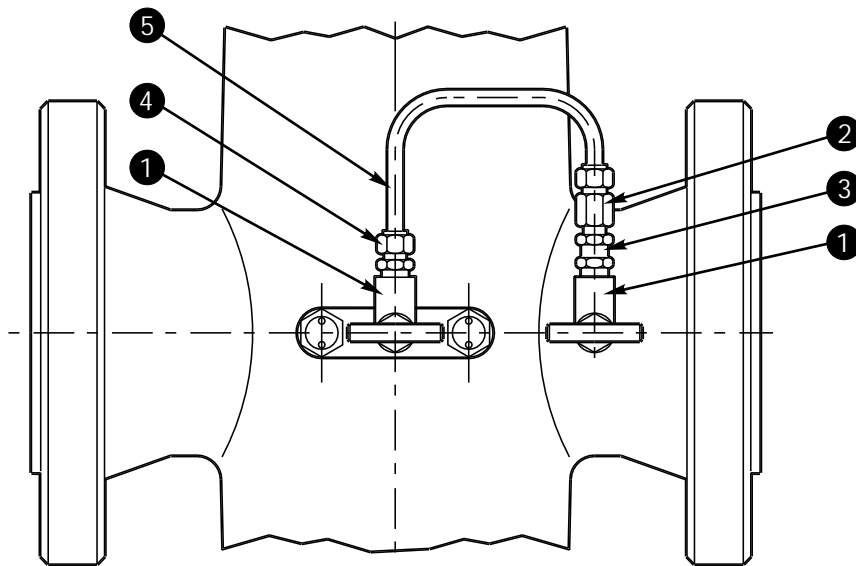

ITEM	PART	QTY
1	Needle Valve	2
2	Female Tubing Connector	1
3	Check Valve	1
4	Male Tubing Connector	1
5	Tubing	1
	Tag (Not Shown)	2
	Wire (Not Shown)	1

- NOTES: (a) These items are on the lettered side of the valve.
 (b) Special Thermal Relief Systems are available upon request.

WKM POW-R-SEAL API 6D THROUGH-CONDUIT GATE VALVES

SUMMARY OF WKM MODEL E-1C POW-R-SEAL GATE VALVE FEATURES

1. THROUGH CONDUIT PARALLEL EXPANDING GATE VALVE
 - a Provides a tight mechanically activated seal.
 - b Full bore design minimizes pressure drop and allows passage of all types of scrapers (pigs).
2. FUGITIVE EMISSIONS TESTED SLS STEM SEAL*
 - a Stem Seal is completely contained in the bonnet.
 - b Stem is centralized by bearings.
 - c Fugitive emissions tested.
 - d Seal is self adjusting and does not depend on plastic packing.
 - e PTFE compound resists virtually all ladings.
 - f Pedestal supports the seal and acts as a stem scraper.
 - g 6 in. - 12 in. (150 mm - 300 mm) 300-900 Class valves are fire tested to API 6FA (3rd Edition).
3. INTERFERENCE FIT SEATS
 - a Block and Bleed per API 6D
 - b Simple design is resistant to dirty service.
 - c Insert initiates the seal and helps clean the gate.**
 - d Seats are compatible with virtually all ladings.
 - e Seats may be lubricated to promote long life, minimize operating torques, or effect a seal in an emergency.
 - f 6 in. - 12 in. (150 mm - 300 mm) 300-900 Class valves are fire tested to API 6FA (3rd Edition).
4. BOLTED BONNET-VALVE IS IN-LINE REPAIRABLE
Bonnet seal resists virtually all ladings.
5. YOKE TUBE UPPER FLANGE CONFORMS TO ISO 5210
(6 in. - 12 in. (150 mm - 300 mm) 300 - 900) and MSS-SP-102
Simplifies operator mounting.
6. SINGLE PIECE CAST BODY CENTER SECTION
 - a Provides the necessary strength to resist pipeline bending.
 - b Smooth shape minimizes stress concentrations.
 - c Made from pressure vessel quality steel.
7. VALVE STROKE IS ESTABLISHED BY MANUFACTURING TOLERANCES
Cannot get out of adjustment.
8. VALVES AVAILABLE WITH HAND WHEEL OPERATORS***, BEVEL GEAR OPERATORS,
OR LESS GEARING (BARE STEM)
Also available with electric motor operators from a variety of suppliers.
9. SEVERAL TYPES OF BODY CAVITY THERMAL RELIEF SYSTEMS ARE AVAILABLE
10. LUBE, PACKING AND DRAIN EXTENSIONS ARE AVAILABLE
11. STEM/YOKE EXTENSIONS ARE AVAILABLE
12. VARIETY OF AVAILABLE PAINTS/COATINGS

* Does not apply to high temperature valves.

** High Temperature valves do not have the insert.

*** 6 in. (150 mm) through 10 in. (250 mm) 300-900 Class and 12 in. (300 mm) 300-600 Class only in selected sizes.

WKM POW-R-SEAL API 6D THROUGH-CONDUIT GATE VALVES

MODEL M

2 in. - 4 in. (50 mm - 100 mm) HANDWHEEL OPERATED

ASME CLASS	MAX.WP @ 100°F (38°C)
600	1500 psi CWP 2250 psi Test
900	2250 psi CWP 3375 psi Test
1500	3750 psi CWP 5625 psi Test

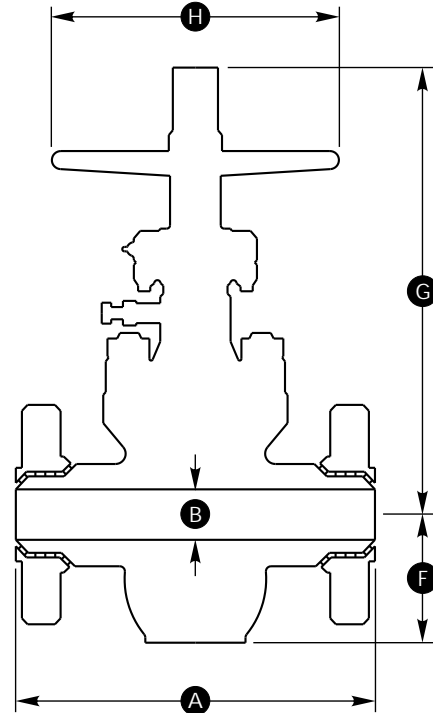

PRINCIPAL DIMENSIONS

N = Number of turns of Handwheel to fully open or close valve.

ASME CLASS 600

Size in. (mm)	A	B	F	G	H	N	Weight lb. (kg)		
							FE	WE	F x W
2 (50)	11 1/2 (292)	2 1/16 (52)	4 13/16 (122)	17 3/4 (451)	12 (305)	16 16	90 (41)	72 (33)	84 (38)
3 (80)	14 (356)	3 3/16 (81)	6 15/16 (176)	23 7/8 (606)	12 (305)	20 20	180 (82)	144 1(65)	155 (70)
4 (100)	17 (432)	4 1/8 (105)	8 5/8 (219)	27 (686)	14 (356)	20 20	345 (156)	259 (117)	245 (111)

ASME CLASS 900

2 (50)	14 1/2 (368)	2 1/16 (52)	5 1/16 (129)	17 3/4 (451)	12 (305)	16 16	150 (68)	72 (33)	105 (48)
3 (80)	15 (381)	3 3/16 (81)	7 5/16 (186)	23 7/8 2(606)	12 (305)	20 20	265 (120)	193 (88)	247 (112)
4 (100)	18 (457)	4 1/8 (105)	9 1/16 (230)	28 1/2 (724)	18 (457)	20 20	515 (234)	390 (177)	417 (189)

ASME CLASS 1500

2 (50)	14 1/2 (368)	2 1/16 (52)	5 1/16 (129)	17 3/4 (451)	12 (305)	16 16	150 (68)	72 (33)	105 (48)
3 (80)	18 1/2 (470)	3 3/16 3(81)	7 5/16 (186)	23 7/8 (606)	12 (305)	20 20	295 (134)	215 (98)	242 (110)
4 (100)	21 1/2 (546)	4 1/8 (105)	9 1/16 (230)	28 1/2 (724)	18 (457)	20 20	530 (240)	403 (183)	325 (147)

Flange dimensions conform to American National Standards Institute Standard B16.5, 1981.
Information on power-actuated and other types of valves available on application.

WKM POW-R-SEAL API 6D THROUGH-CONDUIT GATE VALVES MODEL E1C 6 in. - 12 in. (150 mm - 300 mm) HANDWHEEL OPERATED AND BEVEL GEAR OPERATED

ASME CLASS	MAX.WP @ 100°F (38°C)
300	750 psi CWP 1125 psi Test
600	1500 psi CWP 2250 psi Test
900	2250 psi CWP 3375 psi Test

PRINCIPAL DIMENSIONS

N = Number of turns of Handwheel or Bevel Gear Operator Handwheel to fully open or close valve.

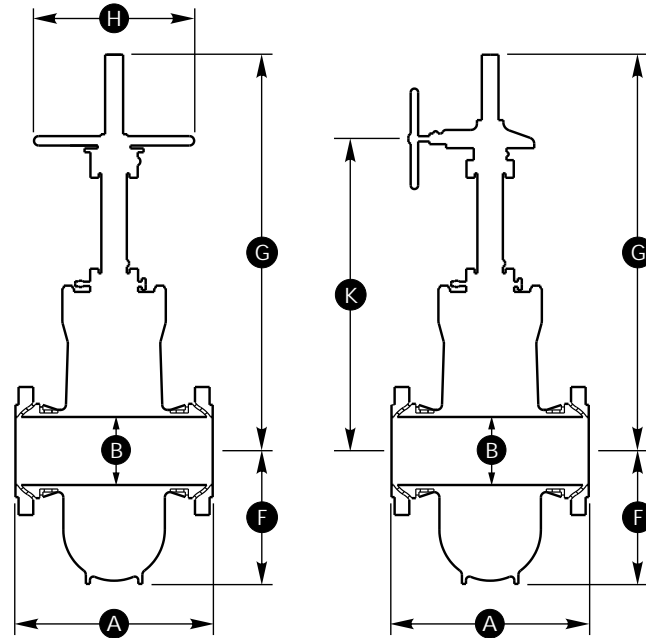

ASME CLASS 300

Size in. (mm)	A	B	F	G		H	K	N		Weight lb. (kg)					
				(HWO)	(BGO)			HWO	BGO	FE	WE	F x W			
6 (150)	15 7/8 (403)	6 (152)	12 1/2 (318)	45 1/4 (1149)	46 1/4 (1175)	24 (610)	30 11/16 (779)	29 29	114 114	472 (214)	397 (180)	400 (181)	500 (227)	445 (202)	470 (213)
8 (200)	16 1/2 (419)	8 (203)	16 (406)	57 1/4 (1454)	56 1/4 (1429)	24 (610)	36 11/16 (932)	37 37	146 146	853 (387)	751 (341)	805 (365)	903 (410)	845 (383)	895 (406)
10 (250)	18 (457)	10 (254)	20 (508)	63 1/4 (1607)	64 1/4 (1632)	24 (610)	44 11/16 (1135)	45 45	180 180	1345 (610)	1200 (544)	1273 (577)	1475 (669)	1380 (626)	1448 (657)
12* (300)	30 (762)	12 (305)	22 3/4 (578)	73 3/8 (1864)	74 5/8 (1895)	30 (762)	51 11/16 (1313)	40 40	239 239	- -	- -	- -	1950 (885)	1670 (757)	1880 (853)

ASME CLASS 600

6 (150)	22 (559)	6 (152)	12 5/8 (321)	45 1/4 (1149)	46 1/4 (1175)	24 (610)	30 11/16 (779)	29 29	114 114	595 (270)	495 (225)	545 (247)	695 (315)	575 (261)	635 (288)
8 (200)	26 (660)	8 (203)	15 1/2 (394)	57 1/4 (1454)	56 1/4 (1429)	24 (610)	36 11/16 (932)	37 37	146 146	1028 (466)	730 (331)	865 (392)	1075 (488)	895 (406)	990 (449)
10 (250)	31 (787)	10 (254)	19 3/4 (502)	64 7/8 (1648)	66 1/8 (1680)	24 (610)	45 3/16 (1148)	34 34	203 203	1735 (787)	1370 (621)	1505 (683)	1895 (860)	1585 (719)	1835 (832)
12 (300)	33 (838)	12 (305)	23 (584)	73 3/8 (1864)	74 5/8 (1895)	30 (762)	51 11/16 (1313)	40 40	239 239	2525 (1145)	2360 (1070)	2480 (1125)	3030 (1374)	2250 (1021)	2360 (1070)

ASME CLASS 900

6 (150)	24 (610)	6 (152)	12 7/8 (327)	45 1/4 (1149)	46 1/4 (1175)	24 (610)	30 3/4 (781)	29 29	114 114	743 (337)	577 (262)	625 (283)	805 (365)	565 (256)	680 (308)
8 (200)	29 (737)	8 (203)	15 3/4 (400)	57 1/4 (1454)	56 1/4 (1429)	24 (610)	36 3/4 (933)	37 37	146 146	1272 (577)	1040 (472)	1180 (535)	1329 (603)	1180 (535)	1238 (562)
10 (250)	33 (838)	10 (254)	20 1/8 (511)	64 7/8 (1648)	66 1/8 (1680)	30 (762)	45 1/4 (1149)	34 34	203 203	2250 (1021)	1930 (875)	2085 (946)	2315 (1050)	1875 (850)	2185 (991)
12 (300)	38 (965)	12 (305)	23 1/2 (597)	- -	73 3/4 (1873)	30 (762)	56 5/8 (1438)	40 40	318 318	3392 (1539)	2725 (1236)	2860 (1297)	3600 (1633)	2880 (1306)	3276 (1486)

* 12 in. (300 mm) 300 Class valves have 400 class End-to-End dimensions.

WKM POW-R-SEAL API 6D THROUGH-CONDUIT GATE VALVES

MODEL E1C

14 in. - 24 in. (350 mm - 600 mm)

BEVEL GEAR OPERATED

ASME CLASS	MAX.WP @ 100°F (38°C)
300	750 psi CWP 1125 psi Test
600	1500 psi CWP 2250 psi Test
900	2250 psi CWP 3375 psi Test

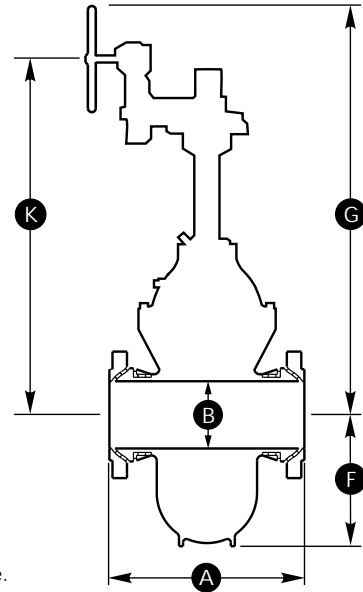

PRINCIPAL DIMENSIONS

N = Number of turns of Bevel Gear Operator Handwheel to fully open or close valve.
ASME CLASS 300

Size in. (mm)	A	B	F	G	K	N	Weight lb. (kg)		
							FE	WE	F x W
14* (350)	30 (762)	13 1/4 (337)	25 1/4 (641)	65 7/8 (1673)	53 (1346)	177 177	2632 (1194)	2230 (1012)	2500 (1134)
16	33 (838)	15 (381)	28 1/8 (714)	83 9/16 (2122)	58 3/8 (1483)	167 167	3450 (1565)	3015 (1368)	3310 (1501)
18	36 (914)	17 (432)	31 (787)	86 13/16 (2205)	65 5/16 (1659)	190 190	4650 (2109)	4260 (1932)	4375 (1984)
20	39 (991)	18 3/4 (476)	35 1/4 (895)	106 1/4 (2699)	73 7/8 (1876)	211 211	6248 (2834)	5780 (2622)	6000 (2722)
24* (600)	45 (1143)	22 3/4 (578)	42 (1067)	115 3/4 (2940)	86 3/8 (2194)	253 253	10678 (4843)	9550 (4332)	10240 (4645)

ASME CLASS 600

14 (350)	35 (889)	13 1/4 (337)	25 9/16 (649)	69 3/4 (1772)	53 1/2 (1359)	177 177	3040 (1379)	2931 (1329)	3000 (1361)
16 (400)	39 (991)	15 (381)	28 1/8 (714)	81 1/8 (2061)	61 1/4 (1556)	167 167	4420 (2005)	3950 (1792)	4160 (1887)
18 (450)	43 (1092)	17 (432)	31 5/8 (803)	86 1/2 (2197)	66 5/8 (1692)	190 190	5705 (2588)	5115 (2320)	5200 (2359)
20 (500)	47 (1194)	18 3/4 (476)	36 (914)	98 1/8 (2492)	73 7/8 (1876)	211 211	7595 (3445)	7115 (3227)	6605 (2996)
24 (600)	55 (1397)	22 3/4 (578)	42 1/4 (1073)	113 1/2 (2883)	87 7/8 (2232)	253 253	12994 (5894)	11380 (5162)	12730 (5774)

ASME CLASS 900

14 (350)	40 1/2 (1029)	12 1/2 (318)	26 1/8 (664)	69 3/4 (1772)	53 1/2 (1359)	- -	5200 (2359)	4902 (2224)	4902 (2224)
16 (400)	44 1/2 (1130)	14 1/4 (362)	30 1/4 (768)	81 1/8 (2061)	66 5/8 (1692)	174 174	7346 (3332)	6435 (2919)	6956 (3155)
18 (450)	48 (1219)	16 3/4 (425)	33 (838)	92 (2337)	- -	- -	11814 (5359)	10226 (4638)	11020 (4999)
20 (500)	52 (1321)	18 5/8 (473)	36 (914)	103 (2616)	- -	- -	15581 (7067)	14265 (6470)	14866 (6743)
24 (600)	61 (1549)	22 1/2 (572)	44 1/2 (1130)	113 1/2 (2883)	87 7/8 (2232)	- -	20467 (9284)	18561 (8419)	19887 (9021)

* 14 in. & 24 in. (350 mm & 600 mm) 300 Class valves have 400 class End-to-End dimensions.

WKM POW-R-SEAL API 6D THROUGH-CONDUIT GATE VALVES

OPERATOR SIZING REQUIREMENTS

MODEL M, 2 in. - 4 in. (50 mm - 100 mm) ASME CLASS 150-1500

Valve Size in. (mm)	ASME Class	ASME Working Pressure (psig)	Stem Thread			Recommended Operating Thrust (lbf)	Recommended Operating Torque (ft-lbf)	Block & Bleed Thrust (lbf)	Block & Bleed Torque (ft-lbf)	Maximum Allowable Thrust (lbf)	Maximum Allowable Torque (ft-lbf)	Total Stem Travel in. (mm)	Turns to Open Valve
			Size in.	Pitch in.	Lead in.								
2 (50)	150	290	0.875	0.167	0.167	457	3	535	4	12597	93	2.63 (67)	15.8
2 (50)	300	750	0.875	0.167	0.167	1183	9	1383	10	12597	93	2.63 (67)	15.8
2 (50)	600	1500	0.875	0.167	0.167	2366	17	2766	20	12597	93	2.63 (67)	15.8
2 (50)	900	2250	0.875	0.167	0.167	3549	26	4149	30	12597	93	2.63 (67)	15.8
2 (50)	1500	3750	0.875	0.167	0.167	5914	43	6915	51	12597	93	2.63 (67)	15.8
3 (80)	150	290	1.000	0.200	0.200	803	7	1115	9	16027	136	4.03 (102)	20.2
3 (80)	300	750	1.000	0.200	0.200	2078	18	2884	25	16027	136	4.03 (102)	20.2
3 (80)	600	1500	1.000	0.200	0.200	4155	35	5769	49	16027	136	4.03 (102)	20.2
3 (80)	900	2250	1.000	0.200	0.200	6233	53	8653	74	16027	136	4.03 (102)	20.2
3 (80)	1500	3750	1.000	0.200	0.200	10388	88	14422	123	16027	136	4.03 (102)	20.2
4 (100)	150	290	1.250	0.250	0.250	1327	14	1783	19	25442	271	4.88 (124)	19.5
4 (100)	300	750	1.250	0.250	0.250	3432	37	4610	49	25442	271	4.88 (124)	19.5
4 (100)	600	1500	1.250	0.250	0.250	6864	73	9221	98	25442	271	4.88 (124)	19.5
4 (100)	900	2250	1.250	0.250	0.250	10297	110	13831	147	25442	271	4.88 (124)	19.5
4 (100)	1500	3750	1.250	0.250	0.250	17161	183	23052	245	25442	271	4.88 (124)	19.5

MODEL E-1C, 6 in. - 24 in. (150 mm - 600 mm) ASME CLASS 300 THROUGH 900

6 (150)	300	750	1.50	0.250	0.250	6626	82	8179	101	21711	267	7.19 (183)	29	
6 (150)	600	1500	1.50	0.250	0.250	13252	163	16358	201	21711	267	7.19 (183)	29	
6 (150)	900	2250	1.50	0.250	0.250	19878	245	24538	302	33158	408	7.19 (183)	29	
8 (200)	300	750	1.75	0.250	0.250	10705	149	12626	176	23678	329	9.12 (232)	36	
8 (200)	600	1500	1.75	0.250	0.250	21410	298	25253	351	26577	370	9.12 (232)	36	
8 (200)	900	2250	1.75	0.250	0.250	32115	447	37879	527	42377	590	9.12 (232)	36	
10 (250)	300	750	2.25	0.333	0.333	16462	296	19385	349	36141	651	11.31 (287)	34	
10 (250)	600	1500	2.25	0.333	0.333	32924	593	38771	698	46433	836	11.31 (287)	34	
10 (250)	900	2250	2.25	0.333	0.333	49386	889	58156	1047	76635	1380	11.31 (287)	34	
12 (300)	300	750	2.25	0.333	0.333	21911	395	27588	497	52472	945	13.38 (340)	40	
12 (300)	600	1500	2.25	0.333	0.333	43822	789	55175	994	64733	1166	13.38 (340)	40	
12 (300)	900	2250	2.25	0.333	0.333	65732	1184	82763	1490	84560	1523	13.38 (340)	40	
14 (350)	300	750	2.00	0.250	0.500	25138	477	32355	614	78209	1485	14.88 (378)		
14 (350)	600	1500	2.00	0.250	0.500	50276	955	64709	1229	78209	1485	14.88 (378)		
14 (350)	900	2250	2.25	0.333	0.333	72608	1308	101857	1835	110039	1982	14.88 (378)		
16 (400)	300	750	2.50	0.400	0.800	33517	868	39174	1015	108946	2822	16.88 (429)		
16 (400)	600	1500	2.50	0.400	0.800	67035	1736	78348	2029	108946	2822	16.88 (429)		
16 (400)	900	2250	2.75	0.400	0.800	97481	2681	146275	4022	162485	4468	17.38 (441)		
18 (450)	300	750	2.50	0.400	0.800	41440	1073	48846	1265	113120	2930	18.94 (481)		
18 (450)	600	1500	2.50	0.400	0.800	82881	2147	97691	2530	113120	2930	18.94 (481)		
18 (450)	900	2250	3.00	0.400	0.400	123194	2901	173424	4084	185236	4362	19.88 (505)		
20 (500)	300	750	2.75	0.400	0.800	51116	1406	60201	1655	113120	3111	21.12 (536)		
20 (500)	600	1500	2.75	0.400	0.800	102231	2811	120401	3311	129553	3562	21.12 (536)		
20 (500)	900	2250	3.25	0.400	0.800	150254	3780	248075	6241	262230	6597	-		
22 (550)	300													No Design
22 (550)	600	1500	3.00	0.400	0.800	123768	3601	149487	4349	118661	3453	23.25 (591)		
22 (550)	900													No Design
24 (600)	300	750	3.00	0.400	0.800	72557	2111	91789	2671	113120	3291	25.25 (641)		
24 (600)	600	1500	3.00	0.400	0.800	145115	4222	183577	5341	203038	5908	25.25 (641)		
24 (600)	900	2250	3.75	0.400	0.800	214524	7273	356572	12089	351789	11927	-		

- NOTE: 1. Use RECOMMENDED OPERATING THRUST and TORQUES for sizing bevel gear operators.
 2. Use BLOCK & BLEED THRUSTS and TORQUES for sizing Power operators (Electric, gas, hydraulic, etc.).
 3. MAXIMUM OPERATING THRUST and TORQUES are the maximum allowable for the valve.

WKM POW-R-SEAL API 6D THROUGH-CONDUIT GATE VALVES OPERATOR INTERFACE DIMENSIONS TOPWORKS

Operator Interface comply with ISO 5210 (6 in. to 12 in. (150 mm to 300 mm) only) and MSS-SP-102. An adapter ring is provided on 6 in. to 12 in. (150 mm to 300 mm) bare stem/less gearing valves to comply with ISO 5210 or MSS-SP-102

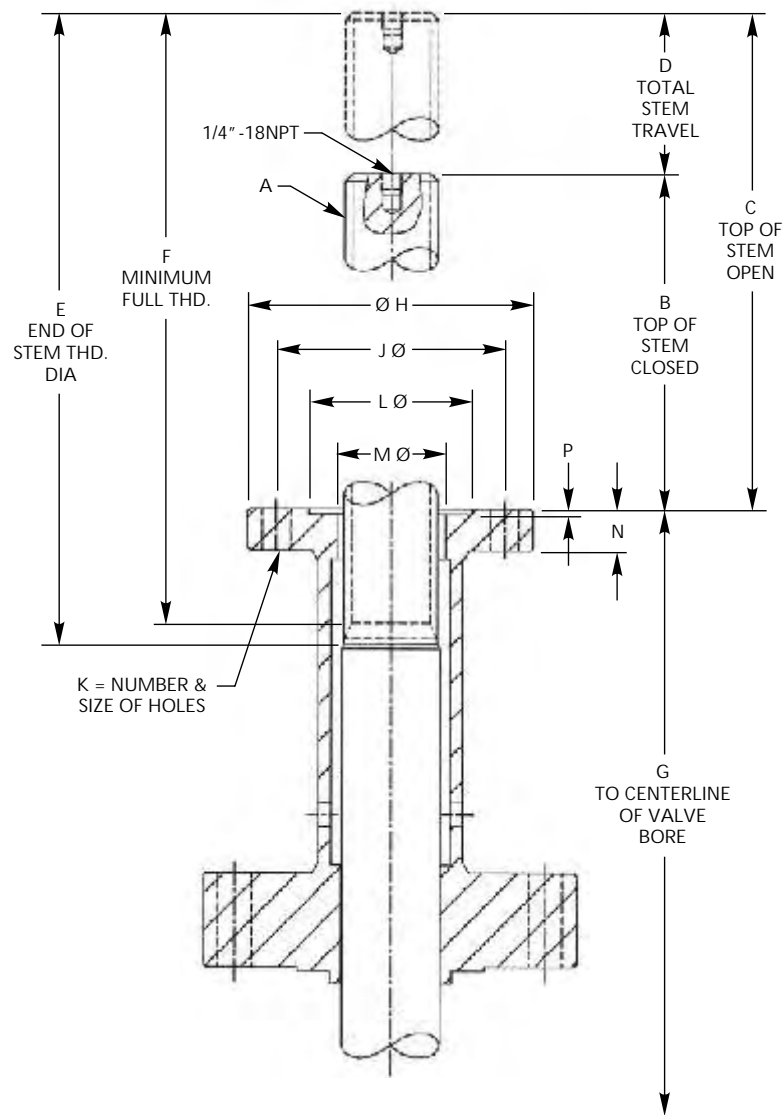

See page 14 for Operator Interface Dimensions.

WKM POW-R-SEAL API 6D THROUGH-CONDUIT GATE VALVES

OPERATOR INTERFACE DIMENSIONS

TOPWORKS

Size in.	Class	MSS Flg	A-NA-2G-L.H.	B	C	D	E	F	G	H	J	K	L	M	N	P
6	309C	FA14	1 1/2 - .250P - .250L Single Lead Thread	8.31	15.50	7.19	16.44	16.06	26.88	7.00	5.50	4 - 0.69	3.955 3.945	2.50	1.03	0.178
8	3-9C	FA14	1 3/4 - .250P - .250L Single Lead Thread	8.44	17.56	9.12	18.94	18.56	32.00	7.00	5.50	4 - 0.69	3.955 3.945	2.50	1.03	0.178
10	3-9C	FA16	2.25 - .333P - .333L Single Lead Thread	9.38	20.69	11.31	24.38	24.00	42.13	8.38	6.50	4 - 0.81	5.230 5.220	3.12 3.75	1.50 2.75	0.230
12	3-6C	FA16	2.25 - .333P - .333L Single Lead Thread	11.50	24.88	13.38	26.06	25.69	45.44	8.38	6.50	4 - 0.81	5.230 5.220	3.12	1.50	0.230
	9C	FA16	2.25 - .333P - .333L Single Lead Thread	11.34	24.75	13.38	26.06	25.69	45.56	8.38	6.50	4 - 0.81	5.230 5.220	3.12	1.50	0.230
14	3-6C	FA16	2 - .250P - .500L Double Lead Thread	9.56	24.38	14.81	27.50	26.88	50.44	8.38	6.50	4 - 0.81	5.230 5.220	3.12	1.50	0.230
16	3-6C	FA25	2 1/2 - .400P - .800L Double Lead Thread	10.19	27.06	16.88	31.19	30.56	56.50	11.50	10.00	8 - 0.69	6.020 6.010	3.75	2.00	0.230
18	3-6C	FA25	2 1/2 - .400P - .800L Double Lead Thread	9.31	28.25	18.94	32.69	32.19	63.88	11.50	10.00	8 - 0.69	6.020 6.010	3.75	2.00	0.230
20	3C	FA25	2 3/4 - .400P - .800L Double Lead Thread	11.50	32.62	21.12	37.00	36.44	70.31	11.50	10.00	8 - 0.69	6.020 6.010	3.75	2.00	0.230
	6C	FA30	2 3/4 - .400P - .800L Double Lead Thread	11.50	32.62	21.12	37.00	36.44	70.31	13.62	11.75	8 - 0.81	7.020 7.010	3.75	2.75	0.230
24	3C	FA25	3 - .400P - .800L Double Lead Thread	12.37	37.62	25.25	43.06	42.56	85.19	11.50	10.00	8 - 0.69	6.020 6.010	3.75	2.00	0.230
	6C	FA35	3 - .400P - .800L Double Lead Thread	12.37	37.62	25.25	43.06	42.56	85.19	16.12	14.00	8 - 1.12	8.520 8.510	4.00	3.25	0.230

Size mm	Class	MSS Flg	A-NA-2G-L.H.	B	C	D	E	F	G	H	J	K	L	M	N	P
150	309C	FA14	38.1 - .250P - .250L Single Lead Thread	211	394	183	418	408	683	178	140	4 - 17.53	100.46 100.20	63.5	26.16	4.52
200	3-9C	FA14	44.45 - .250P - .250L Single Lead Thread	214	446	232	481	471	813	178	140	4 - 17.53	100.46 100.20	63.5	26.16	4.52
250	3-9C	FA16	57.15 - .333P - .333L Single Lead Thread	238	526	287	619	610	1070	213	165	4 - 20.57	132.84 132.59	79.25 95.25	38.1 69.85	5.84
300	3-6C	FA16	57.15 - .333P - .333L Single Lead Thread	292	632	340	662	653	1154	213	165	4 - 20.57	132.84 132.59	79.25	38.1	5.84
	9C	FA16	57.15 - .333P - .333L Single Lead Thread	288	629	340	662	653	1157	213	165	4 - 20.57	132.84 132.59	79.25	38.1	5.84
350	3-6C	FA16	50.8 - .250P - .500L Double Lead Thread	243	619	376	699	683	1281	213	165	4 - 20.57	132.84 132.59	79.25	38.1	5.84
400	3-6C	FA25	63.5 - .400P - .800L Double Lead Thread	259	687	429	792	776	1435	292	254	8 - 17.53	152.91 152.65	95.25	50.8	5.84
450	3-6C	FA25	63.5 - .400P - .800L Double Lead Thread	9.31	718	481	830	818	1623	292	254	8 - 17.53	152.91 152.65	95.25	50.8	5.84
500	3C	FA25	69.85 - .400P - .800L Double Lead Thread	292	829	536	940	926	1786	292	254	8 - 17.53	152.91 152.65	95.25	50.8	5.84
	6C	FA30	69.85 - .400P - .800L Double Lead Thread	292	829	536	940	926	1786	346	298	8 - 20.57	178.31 178.10	95.25	69.85	5.84
600	3C	FA25	76.2 - .400P - .800L Double Lead Thread	314	956	641	1094	1081	2164	292	254	8 - 17.53	152.91 152.65	95.25	50.8	5.84
	6C	FA35	76.2 - .400P - .800L Double Lead Thread	314	956	641	1094	1081	2164	409	356	8 - 28.45	216.41 216.15	101.6	82.55	5.84

WKM POW-R-SEAL API 6D THROUGH-CONDUIT GATE VALVES FLOW COEFFICIENTS (C_v)

The following chart outlines the C_v for through conduit gate valves having end-to-end dimensions and bore diameters in compliance with API 6D.*
Since C_v is a calculated number, the actual value may vary.

Valve Size in.	300	400	600	900	1500	2500
2	432	378	378	337	337	218
3 x 2	-	165	165	203	239	-
2 1/2	-	682	682	558	558	305
3	1155	1053	1109	1072	966	474
4 x 3	-	534	529	597	677	624
4	2176	1925	1944	1890	1730	725
6 x 4	-	886	944	943	1231	-
6	5300	4860	4577	4383	3622	2510
8 x 6	2499	-	3240	3588	2137	-
8	11054	9345	8886	8416	6879	5227
10 x 8	5218	-	5036	7975	4859	-
12 x 8	3302	-	3892	-	-	-
10	18856	15771	14533	14087	11283	8313
12 (Note 1)	228980	23834	22729	21025	16843	12282
12 x 10	-	-	12799	7299	-	-
14 (Note 1)	30883	29921	28837	23846	20336	-
16 x 14	-	-	21096	-	-	-
16	42224	41022	39144	33358	27548	21396
20 x 16	-	15761	-	-	-	-
18	55740	54277	51368	45004	-	-
20	70386	68680	64559	56871	-	-
22	86869	85422	80279	-	-	-
24 (Note 1)	106835	103504	97240	84836	-	-
26	123222	120829	114905	-	-	-
28	144355	142391	135267	-	-	-
30	170229	163776	157401	133706	-	-
36	245362	236147	224424	-	-	-

* As Applicable.

Notes: 1. 300 Class valves have 400 Class end-to-ends in these size Pow-R-Seal designs.
Use the 400 Class C_v .

WKM POW-R-SEAL API 6D THROUGH-CONDUIT GATE VALVES FLOW COEFFICIENTS (K_v)

The following chart outlines the K_v for through conduit gate valves having end-to-end dimensions and bore diameters in compliance with API 6D.*
Since K_v is a calculated number, the actual value may vary.

Valve Size in.	300	400	600	900	1500	2500
2	373	327	327	291	291	188
3 x 2	-	142	145	175	207	-
2 1/2	-	590	590	483	483	264
3	999	911	959	927	835	410
4 x 3	-	462	458	516	585	540
4	1882	1665	1682	1635	1496	627
6 x 4	-	766	817	816	1065	-
6	4585	4204	3959	3792	3133	2172
8 x 6	2162	-	2803	3103	1849	-
8	9562	8084	7687	7280	5951	4522
10 x 8	4514	-	4356	6898	4204	-
12 x 8	2857	-	3367	-	-	-
10	16312	13643	12572	12186	9761	7191
12 (Note 1)	25070	20617	19662	18188	14570	10624
12 x 10	-	-	11072	6314	-	-
14 (Note 1)	26715	25883	24945	20628	17591	-
14 x 12	-	-	-	-	-	-
16 x 14	-	-	18249	-	-	-
16	36526	35486	33862	28856	23831	18509
20 x 16	-	13634	-	-	-	-
18	48218	46953	44436	38930	-	-
20	60888	59412	55847	49196	-	-
22	75147	73894	69445	-	-	-
24 (Note 1)	92417	89536	84117	73388	-	-
26	106593	104523	99399	-	-	-
28	124874	123175	117013	-	-	-
30	147257	141674	136160	115662	-	-
40 x 30	-	-	-	60464	-	-
36	212251	204279	194138	-	-	-
42 x 36	70357	-	-	-	-	-
40	266697	265814	265814	-	-	-
42	-	302576	293854	-	-	-
48	-	-	408871	-	-	-

* As Applicable.

Note: 1. 300 Class valves have 400 Class end-to-ends in these size Pow-R-Seal designs.
Use the 400 Class K_v .

WKM POW-R-SEAL API 6D THROUGH-CONDUIT GATE VALVES PARTIAL OPEN FLOW CHARACTERISTICS

The following graph approximates Flow Coefficient (C_v or K_v) of gate valves as a function of the valve stroke going from CLOSED to OPEN. Note that this is an estimation only because of assumptions made in the valve stroke as well as unpredictable flow characteristics around the gate-seat bore in the partially open position.

Gate valves are intended for on-off service. Intermittent throttling such as pressure equalization service is acceptable. Continuous throttling is not recommended. This information is provided only to facilitate the engineering of systems in the transition between open and closed positions of the valves. One example might be to evaluate the possibility of water hammer in liquid pipelines.

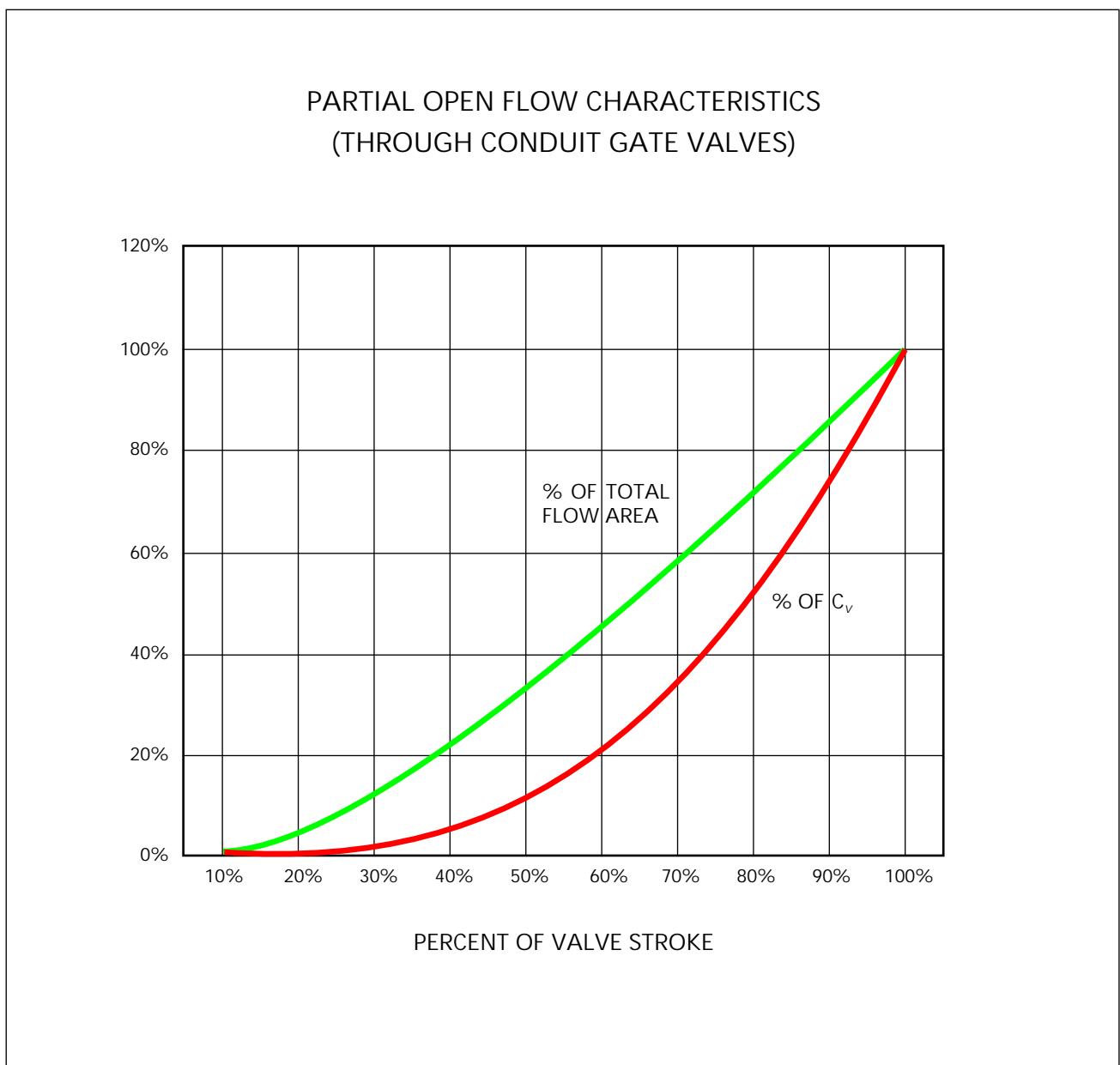

WKM POW-R-SEAL API 6D THROUGH-CONDUIT GATE VALVES PRESSURE TEMPERATURE RATINGS WITH STANDARD WCC MATERIAL

Temperature		Working Pressure by Class,psig					
°C	°F	150	300	400	600	900	1500
-29°C to 38°C	-20°F to 100°F	290	750	1000	1500	2250	3750
93°C	200°F	260	750	1000	1500	2250	3750
149°C	300°F	230	730	970	1455	2185	3640
204°C	400°F	200	705	940	1410	2115	3530
260°C	500°F	170	665	885	1330	1995	3325
316°C	600°F	140	605	805	1210	1815	3025
343	650°F	125	590	785	1175	1765	2940
371°C	700°F	110	570	755	1135	1705	2840
399°C	750°F	95	505	670	1010	1510	2520
427°C	800°F	80	410	550	825	1235	2060

REF.: API 6D, ASME B16.34

Temperature		Working Pressure by Class, bar				
°C	°F	150	300	600	900	1500
-29°C to 38°C	-20°F to 100°F	19.8	51.7	103.4	155.1	258.6
50°C	122°F	19.5	51.7	103.4	155.1	258.6
100°C	212°F	17.7	51.5	103.0	154.6	257.6
150°C	302°F	15.8	50.2	100.3	150.5	250.8
200°C	392°F	13.8	48.6	97.2	145.8	243.2
250°C	482°F	12.1	46.3	97.2	139.0	231.8
300°C	572°F	10.2	42.9	85.7	128.6	214.4
325°C	617°F	9.3	41.4	82.6	124.0	206.6
350°C	662°F	8.4	40.0	80.0	120.1	200.1
375°C	707°F	7.4	37.8	75.7	113.5	189.2
400°C	752°F	6.5	34.7	69.4	104.2	173.6
425°C	797°F	5.5	28.8	57.5	86.3	143.8

General Note: (a) Flanged End Valve ratings terminate at 538°C (1000°F).

WKM POW-R-SEAL API 6D THROUGH-CONDUIT GATE VALVES PRESSURE TEMPERATURE RATINGS WITH STANDARD WC6 MATERIAL

Temperature		Working Pressure by Class, psig				
°C	°F	150	300	600	900	1500
-29°C to 38°C	-20°F to 100°F	290	750	1,500	2,250	3,750
93°C	200°F	260	750	1,500	2,250	3,750
149°C	300°F	230	720	1,445	2,165	3,610
204°C	400°F	200	695	1,385	2,080	3,465
260°C	500°F	170	665	1,330	1,995	3,325
316°C	600°F	140	605	1,210	1,815	3,025
343°C	650°F	125	590	1,175	1,765	2,940
371°C	700°F	110	570	1,135	1,705	2,840
399°C	750°F	95	530	1,065	1,595	2,660
427°C	800°F	80	510	1,015	1,460	2,540
454°C	850°F	65	485	975	1,350	2,435
482°C	900°F	50	450	900	955	2,245
510°C	950°F	35	320	640	650	1,595
538°C	1000°F	20	215	430	430	1,080

Temperature		Working Pressure by Class, bar				
°C	°F	150	300	600	900	1500
-29°C to 38°C	-20°F to 100°F	19.8	51.7	103.4	155.1	258.6
50°C	122°F	19.5	51.7	103.4	155.1	258.6
100°C	212°F	17.7	51.5	103.0	154.4	257.4
150°C	302°F	15.8	49.7	99.5	149.2	248.7
200°C	392°F	13.8	48.0	95.9	143.9	239.8
250°C	482°F	12.1	46.3	92.7	139.0	231.8
300°C	572°F	10.2	42.9	85.7	128.6	214.4
325°C	617°F	9.3	41.4	82.6	124.0	206.6
350°C	662°F	8.4	40.3	80.4	120.7	201.1
375°C	707°F	7.4	38.9	77.6	116.5	194.1
400°C	752°F	6.5	36.5	73.3	109.8	183.1
425°C	797°F	5.5	35.2	70.0	105.1	175.1
450°C	842°F	4.6	33.7	67.7	101.4	169.0
475°C	887°F	3.7	31.7	63.4	95.1	158.2
500°C	932°F	2.8	25.7	51.5	77.2	128.6
538°C	1000°F	1.4	14.9	29.8	44.7	74.5

General Note: (a) Flanged End Valve ratings terminate at 538°C (1000°F).

WKM POW-R-SEAL API 6D THROUGH-CONDUIT GATE VALVES TRIMS

T-10 WATERFLOOD (UNINHIBITED)

Carbon steel body/bonnet with wetted surface, ENP plated, internal parts of corrosive resistant materials.

Temperature ratings: -20°F to +250°F (-29°C to +121°C).

T-11 MODEL M - 2 inch, 3 inch, 4 inch, ASME CLASS 600 -1500 STANDARD TRIM

For non-corrosive aromatic service with concentration of MTBE to 100 percent.

Temperature rating: -20°F to +250°F (-29°C to +121°C).

T-24 SOUR GAS AND OIL (NACE MR0175)

Primarily for sour gas and oil (NACE MR0175) where resistance to hydrogen sulfide embrittlement is required. Also suitable for other chemicals, products or hydrocarbons when H₂S is present. May be used when CO₂ is present in smaller amounts than H₂S.

Temperature ratings: -20°F to +250°F (-29°C to +121°C).

T-30 High TEMPERATURE -20°F TO +650°F (-29°C TO 343°C)

For higher temperature service where the corrosion resistance and wire drawing resistance of the stainless internals with stellite overlay are suitable.

The limiting temperature is a function of the body material which follows the appropriate pressure rating table. (Ref. ASME Std. B16.34, 1977).

The temperature limitations are -20°F to +650°F (-29°C to +343°C).

T-31 High TEMPERATURE - UP TO +1000°F (+538°C)

For service above 550°F (288°C). Has same qualifications as T-30, except metal-to-metal seating only is required for temperatures from +650°F to +1000°F (+343°C to +538°C).

T-36 LOW TEMPERATURE - 50°F (-46°C) NACE

For essentially non-corrosive ladings, either liquid or gaseous.

The pressure retaining components (body, bonnet and bolting) are of impact tested materials.

Temperature ratings: -50°F to +250°F (-46°C to +121°C).

T-37 LOW TEMPERATURE SOUR -50°F (-46°C) NACE

Primarily for sour gas and oil (NACE MR0175) where resistance to hydrogen sulfide embrittlement is required at -50°F (-46°C) service.

The pressure retaining components (body, bonnet and bolting) are of impact tested materials.

Also suitable for other chemicals, products or hydrocarbons when H₂S is present.

May be used when CO₂ is present in smaller amounts than H₂S.

Temperature ratings: -50°F to +250°F (-46°C to +121°C).

T-102 HIGH AROMATIC (TO 100% MTBE) 6 inch - 24 inch 300 - 900

For non-corrosive aromatic service with concentration of MTBE to 100 percent.

Temperature rating: -20°F to +250°F (-29°C to +121°C).

Other Trims Available on Request.

WKM POW-R-SEAL API 6D THROUGH-CONDUIT GATE VALVES TRIM CHART

Service	Trim Code	Body & Bonnet	Gate & Segment	Seat	Stem Seal	Stem	Bolting	Fittings
Waterflood, Corrosive -20°F to 250°F -29°C to 121°C	T-10	WCC Carbon Steel, Nickel Plated	Carbon Steel 300- 600, Low Alloy 900 Nickel Plated	Carbon Steel, Nickel Plated PTFE Insert	PTFE	Low Alloy Steel, Nickel Plated	Alloy Steel NACE	Stainless Steel
Standard -20°F to 250°F -29°C to 121°C	T-11 2 - 4 in. only	WCC Carbon Steel	Carbon Steel, Low Alloy Steel, Nickel Plated	Carbon Steel, Nickel Plated PTFE Insert	FKM Viton	Low Alloy Steel, Nickel Plated	Alloy Steel	Carbon Steel
Sour, Mildly Corrosive -20°F to 250°F -29°C to 121°C	T-24 2 in. & larger	WCC Carbon Steel	Carbon Steel 300- 600, Low Alloy 900 Nickel Plated	Carbon Steel, Nickel Plated PTFE Insert	PTFE	Low Alloy Steel, Nickel Plated	Alloy Steel NACE	Stainless Steel
High Temperature -20°F to 650°F -29°C to 343°C	T-30	WCC Carbon Steel	CA6NM Stainless Steel, HF-6 Hard Faced	Carbon Steel, HF-6 Hard Faced	Flexible Graphite	400 Series Stainless Steel	Alloy Steel	Stainless Steel
High Temperature -20°F to 1000°F -29°C to 538°C	T-31	WC6 Carbon Steel	CA6NM Stainless Steel, HF-6 Hard Faced	A182 F11 Carbon Steel, HF-6 Hard Faced	Flexible Graphite	400 Series Stainless Steel	Alloy Steel	Stainless Steel
Low Temperature, Non-Sour -50°F to 250°F -46°C to 121°C	T-36	LCC Carbon Steel Impact Tested	Nickel Plated LCC Carbon Steel 300-600 Class Low Alloy Steel 900 Class	Carbon Steel, Nickel Plated PTFE Insert	PTFE	Low Alloy Steel, Impact Nickel Plated	Alloy Steel, Impact Tested	Stainless Steel
Low Temperature, Sour -50°F to 250°F -46°C to 121°C	T-37	LCC Carbon Steel Impact Tested	Nickel Plated LCC Carbon Steel 300-600 Class Low Alloy Steel 900 Class	Carbon Steel, Nickel Plated PTFE Insert	PTFE	Low Alloy Steel, Impact Nickel Plated	Alloy Steel, NACE, Impact Tested	Stainless Steel
Standard -20°F to 250°F -29°C to 121°C	T-102 6 in. & larger	WCC Carbon Steel	Carbon Steel 300- 600, Low Alloy 900 Nickel Plated	Carbon Steel, Nickel Plated PTFE Insert	PTFE	Low Alloy Steel, Nickel Plated	Alloy Steel	Carbon Steel

WKM POW-R-SEAL API 6D THROUGH-CONDUIT GATE VALVES APPLICATIONS



WKM Model D High Temperature Pow-R-Seal Gate Valves in a Synthetic Natural Gas Plant



Technician demonstrating bonnet removal and in-line repair of WKM Model E



WKM Model D Pow-R-Seal Gate Valve acting as a block valve in a pipeline expansion



WKM Model E Pow-R-Seal Gate Valves on a gas storage manifold



WKM Model G Series Pow-R-Seal Gate Valve with a gas motor operator

WKM POW-R-SEAL API 6D THROUGH-CONDUIT GATE VALVES APPLICATIONS



WKM Model E1 Pow-R-Seal Gate Valve used for isolation of a control valve in a liquids pipeline



WKM Model E Pow-R-Seal Gate Valves on the inlet to a gas sweetening plant



18 inch (450 mm) 600 WKM Model E Pow-R-Seal Gate Valve in a block valve application



WKM Model G Series Pow-R-Seal Gate Valve in a block valve application on a pipeline loop - possibly a pigging loop. Note smaller WKM Model D Pow-R-Seals possibly used as "kicker valves"



WKM Model E Pow-R-Seal Gate Valve used for switching gasoline and other refined products on a tank farm manifold



WKM Model E Pow-R-Seal Gate Valves on an LPG storage wellhead

TRADEMARK INFORMATION

WKM® is a registered trademark which is owned by Cameron.

This document contains references to registered trademarks or product designations, which are not owned by Cameron.

Trademark	Owner
Inconel	INCO Nickel Sales, Inc.
Monel	INCO Alloys International, Inc.
Stellite	Stoody Deloro Stellite, Inc.
Teflon	E.I. DuPont De Nemours & Company
Viton	E.I. DuPont De Nemours & Company

CAMERON, VALVES & MEASUREMENT TERMS AND CONDITIONS OF SALE

1. CONTRACT ACCEPTANCE:

Any written or oral purchase order received from Buyer by Seller shall be construed as a written acceptance of Seller's offer to sell and shall be filled in accordance with the terms and conditions of sale set forth herein. SELLER'S ACCEPTANCE OF THIS ORDER IS EXPRESSLY CONDITIONED ON BUYER'S ASSENT TO THE TERMS CONTAINED HEREIN. The terms and conditions of Seller's proposal (if any) and acknowledgement shall prevail over any conflicting or different terms in Buyer's order unless Buyer notifies Seller in writing of its objections thereto within fifteen (15) days from receipt of Seller's acknowledgement. Buyer's standard terms of purchase will not be considered a counteroffer to Seller's terms and conditions of sale. The failure of Seller to object to any provision in conflict herewith whether contained on Buyer's purchase order or otherwise shall not be construed as a waiver of the provisions hereof nor as an acceptance thereof.

2. QUOTATIONS AND PRICES:

Any product, service capability or manufacturing capability which may be available at the time a quotation is made is subject to prior sale. Prices quoted are subject to change without notice. The price in effect at the time of shipment including any escalation formula will apply, unless a valid quotation or written agreement to the contrary exists between Buyer and Seller. All prices shown are in U.S. dollars and are F.O.B. Seller's shipping point. Seller reserves the right to place a service charge on past due accounts at the highest rate permitted by law. Any documentation pertaining to traceability requirements for raw materials or products or documentation required for any routine or special processes must be identified by the Buyer at the time of quotation (if any) or at the time of order placement.

3. TAXES:

Any tax or other charge imposed by law on the sale or production of goods or the performance of services shall be paid by the Buyer, unless the law specifically provides that such payment must be made by Seller, in which case Buyer shall reimburse Seller for such payment as part of the purchase price. Custom duties, consular fees, insurance charges and other comparable charges will be borne by Buyer.

4. SHIPPING SCHEDULE AND DELIVERY:

Shipment schedules are given as accurately as conditions permit and every effort will be made to make shipments as scheduled. Seller will not be responsible for deviations in meeting shipping schedules nor for any losses or damages to Buyer (or any third party) occasioned by deviations in the shipping schedule, whether due to Acts of God, orders bearing priority ratings established pursuant to law, differences with workmen, local labor shortages, fire, flood, shortages or failure of raw materials, supplies, fuel, power or transportation, breakdown of equipment or any other causes beyond Seller's reasonable control, whether of similar or dissimilar nature than those enumerated. Seller shall have additional time within which to perform as may be reasonably necessary under the circumstances and shall have the right to apportion its production among its customers in such a manner as it may consider to be equitable. Seller reserves the right to furnish commercially equivalent or better substitutes for materials or to subcontract the Buyer's order or portions thereof as Seller deems necessary. In no event shall Seller be liable for any consequential damages resulting from failure or delay in shipment. If Buyer requires drawings, procedures, standards or similar material for approval, shipping schedules will be calculated from the time such approvals are received by Seller, since shipping schedules are based on Seller having all required information and a firm order from Buyer which is enterable into production. Any hold points, witness points or the need for inspection by Buyer's representatives must be identified by Buyer at the time of quotation (if any) and/or order placement in order that the effect on the prices or shipping schedules (if any) can be taken into account. Additional inspection or testing required by Buyer which affects normal production sequence will be considered as extending the shipping dates accordingly.

5. TERMS OF PAYMENT:

Terms of payment are 30 days from date of invoice unless otherwise stated in the quotation or Seller's order acknowledgment.

6. CANCELLATIONS AND RETURNS:

Purchase orders once placed by Buyer and accepted by Seller can be canceled only with Seller's written consent and upon terms which will save Seller from loss. No products may be returned for credit or adjustment without written permission from Seller's office authorized to issue such permission.

7. WARRANTIES:

All products of Seller's manufacture except for its Orbit product are warranted against defects of material and workmanship for a period of twelve (12) months from the date of installation or eighteen (18) months from date of shipment, whichever period first expires while its Orbit product is warranted for thirty six (36) months from date of shipment, when all such products are used in the service and within the pressure range for which they were manufactured. In the case of products or parts not wholly of Seller's manufacture, Seller's liability shall be limited to the extent of its recovery from the manufacturer of such products or parts under its liability to Seller. Any repair work performed by Seller is warranted for one year from completion of such repairs and applies only to work performed. If, within these specified periods, Seller receives notice from Buyer of any alleged defect in or nonconformance of any product or repair and if in the Seller's sole judgment the product or repair does not conform or is found to be defective in material or workmanship, then, Buyer shall, at Seller's request, return the part or product F.O.B. to Seller's designated plant or service location. Seller has no liability for removal or reinstallation of products or equipment. Seller, at its option and expense, shall repair or replace the defective part or product, or repay to Buyer the full price paid by Buyer for such defective part, repair or product. Any repayment of purchase price shall be without interest. Seller's warranty liability, including defects caused by Seller's negligence, shall be limited to such repair, replacement or refund, and shall not include claims for labor costs, expenses of Buyer resulting from such defects, recovery under general tort law or strict liability or for damages resulting from delays, loss of use, or other direct, indirect, incidental or consequential damages of any kind. Seller will not be responsible for failures of products which have been in any way tampered with or altered by anyone other than an authorized representative of Seller, failures due to lack of compliance with recommended maintenance procedures or products which have been repaired or altered in such a way (in Seller's judgment) as to affect the products adversely. THIS WARRANTY IS EXPRESSLY IN LIEU OF ALL OTHER WARRANTIES, EXPRESS, STATUTORY OR IMPLIED, INCLUDING THE WARRANTY OF MERCHANTABILITY AND FITNESS FOR PARTICULAR PURPOSE WHICH EXCEED THE FOREGOING WARRANTY.

8. ENGINEERING AND SERVICE:

Upon request, Seller will provide engineering and/or technical information regarding its products and their uses and, if feasible, will provide personnel to assist Buyer in effecting field installations and/or field service. Any such information, service or assistance so provided, whether with or without charge, shall be advisory only.

9. LABOR STANDARDS:

Seller hereby certifies that these products were produced in accordance with all applicable requirements of Section 6, 7 and 12 of the Fair Labor Standards Act as amended and of regulations and orders of the United States Department of Labor issued under Section 14 thereof.

10. INSPECTION:

Unless otherwise agreed in writing, final inspection and acceptance of products must be made at Seller's plant or other shipping or receiving point designated by Seller and shall be conclusive except as regards latent defects. Buyer's representatives may inspect at the Seller's plant or shipping point during working hours prior to shipment in such manner as will not interfere with operations.

11. DELIVERY AND ACCEPTANCE:

Delivery shall be in accordance with the requirements in the Purchase Contract, provided, in the event Buyer is unable to accept delivery upon completion of the manufacture of the Goods in accordance with such requirements, Buyer agrees that (i) title and risk of ownership shall pass to Buyer on date of Seller's invoice, and (ii) Buyer will make payments within thirty days after date of such invoice. Seller shall retain custodial risk of loss until delivery is made in accordance with such requirements.

12. EXPORT COMPLIANCE:

The Buyer shall provide the Seller with relevant end-use, end-user and country of end-use information with respect to the goods, services, software or technology to be supplied hereunder (collectively, "Items"). Based on and in reliance on such information, the Seller will supply such Items in compliance with applicable trade and customs laws including that of the United States of America. The Seller cautions and the Buyer acknowledges that any change in end-use, end-user or country of end-use (including a shipment between countries other than the U.S.) may be restricted or prohibited by applicable trade and

customs law, whether it be of the U.S. or other country. The Parties shall comply with all trade and customs laws (including U.S. Export Controls) except for any such laws which conflict with or are otherwise penalized under the laws of the U.S., which in the event of such conflict, Seller shall notify Buyer. The Buyer agrees in particular that it shall not use and shall not permit any third party to use such items in connection with the design, production, use, or storage of chemical, biological or nuclear weapons or missiles of any kind.

13. TRANSPORTATION CHARGES, ALLOWANCES, CLAIMS:

All prices are F.O.B. Seller's plant or other designated shipping point. No freight is allowed unless stated in Seller's quotation (if any) or in a written contract which may exist between Seller and Buyer at the time of shipment. If Seller's quotation or a written contract states that all or a portion of freight is allowed, all prices are F.O.B. Seller's plant or other designated shipping point, with most economical surface transportation allowed. If the quoted or contractual price includes transportation, Seller reserves the right to designate the common carrier and to ship in the manner it deems most economical. Added costs due to special routing requested by the Buyer are chargeable to the Buyer. Under no circumstances is any freight allowance which is absorbed by Seller to be deducted from the selling price. If the quoted price or contract includes transportation, no deduction will be made in lieu thereof whether Buyer accepts shipment at plant, warehouse, freight station, or otherwise supplies its own transportation. When sales are made from the Seller's warehouse, Seller reserves the right to charge either actual or pro-rated freight from Seller's principle point of manufacture to Seller's warehouse. Buyer assumes risk of loss upon delivery to the carrier, regardless of who pays shipping costs. Seller endeavors to pack or prepare all shipments so that they will not break, rust or deteriorate in transit, but does not guarantee against such damage. Unless requested in writing by the Buyer, no shipments are insured by Seller against damage or loss in transit. Seller will place insurance as nearly as possible in accordance with Buyer's written instructions but in such case Seller acts only as agent between the insurance company and the Buyer and assumes no liability whatsoever. Any claims for shipping loss, breakage or damage (obvious or concealed) are Buyer's responsibility and should be made to the carrier. All claims regarding shortages must be made within thirty (30) days from receipt of shipment and must be accompanied by the packing list(s) covering the shipment.

14. INDEMNIFICATION AND LIMITATION OF LIABILITY:

A. INDEMNIFICATION:

"Buyer Group" means: Buyer, its parent (if any), subsidiaries, affiliates, co-owners, co-venturers, partners and any entity with whom Buyer has an economic interest with respect to the Work including Buyer's customer and its and their respective employees, personnel, directors, officers, borrowed servants, representatives, agents, contractors and subcontractors (respectively and of any tier or level and who are not included within the Seller Group), "Seller Group" means: Seller, its parent (if any), subsidiaries, affiliates, co-owners and its and their respective employees, personnel, directors, officers, borrowed servants, representatives, agents, contractors and subcontractors (respectively and of any tier or level and who are not included within the Buyer Group), "Negligence" means: sole, joint or concurrent, active, passive, gross or willful misconduct.

(1) Seller shall release, defend, save, indemnify (collectively "Indemnify") and hold Buyer Group harmless from and against all claims, demands, losses, damages and causes of action of whatever kind or nature (collectively "Claims"), for loss of or damage to the property of the members of the Seller Group even if such Claims arise from or attributable to the Negligence of the members of Buyer Group.

(2) Seller shall Indemnify and hold Buyer Group harmless from and against all Claims for the death(s) of or personal injury(ies) to members of the Seller Group even if such Claims arise from or attributable to the Negligence of the members of Buyer Group.

(3) Buyer shall Indemnify and hold Seller Group harmless from and against all Claims for loss of or damage to the property (including the Work) of the members of the Buyer Group even if such Claims arise from or attributable to the Negligence of the members of Seller Group.

(4) Buyer shall Indemnify and hold Seller Group harmless from and against all Claims for the death(s) of or personal injury(ies) to members of the Buyer Group even if such Claims arise from or attributable to the Negligence of the members of Seller Group.

(5) Buyer (on its own behalf and on behalf of Buyer Group) and Seller (on its own behalf and on behalf of Seller Group) shall Indemnify and hold each other harmless from and against any and all Claims asserted against them by or on behalf of any third party for the death(s) of or personal injury (ies) to such a third party, as well as loss (es) of or damage(s) to the property of such a third party. A third party is a person or entity not included in Buyer Group or Seller Group. It is agreed by Buyer and Seller that their respective duty of indemnity to each other with respect to Claims asserted against them by a third party pursuant to this Article 14 (A) (5) shall be limited to their respective degree of Negligence.

(6) Notwithstanding any other provision contained in this Agreement, Buyer shall Indemnify and hold the members of Seller Group harmless from and against all Claims (including clean-up costs and loss (es) of oil, gas or hydrocarbons) arising from pollution, contamination, dumping or spilling of any substance and even if arising out of or attributable to the Negligence of the members of the Seller Group.

B. INDEMNITY FOR CONSEQUENTIAL DAMAGES:

UNDER NO CIRCUMSTANCES SHALL SELLER BE LIABLE FOR ANY SPECIAL, CONSEQUENTIAL, INCIDENTAL, EXEMPLARY OR PUNITIVE DAMAGES (collectively "CONSEQUENTIAL"). AS DEFINED BY THE LAWS GOVERNING THIS PURCHASE ORDER, NOR FOR ANY LOSS OF ANTICIPATED PROFITS, LOSS OF BUSINESS OPPORTUNITY, LOSS OF USE OF EQUIPMENT OR OF ANY INSTALLATION, SYSTEM OR FACILITY INTO WHICH SELLER'S EQUIPMENT MAY BE LOCATED OR AT WHICH MEMBERS OF THE SELLER GROUP MAY BE PERFORMING WORK AND BUYER AGREES TO "INDEMNIFY" AND HOLD SELLER GROUP HARMLESS FROM AND AGAINST ANY "CLAIMS" FOR SUCH "CONSEQUENTIAL" DAMAGES EVEN IF ARISING OUT OF OR ATTRIBUTABLE TO THE "NEGLIGENCE" OF THE MEMBERS OF THE SELLER GROUP.

C. LIMITATION OF LIABILITY:

EXCEPT AS OTHERWISE EXPRESSLY LIMITED IN THIS AGREEMENT IT IS THE EXPRESS INTENTION OF THE PARTIES HERETO THAT ALL INDEMNITY OBLIGATIONS AND/OR LIABILITIES HEREBY ASSUMED BY THE PARTIES SHALL BE: (i) SUPPORTED BY INSURANCE; (ii) WITHOUT LIMIT; (iii) AND WITHOUT REGARD TO THE CAUSE OR CAUSES THEREOF, INCLUDING, BUT NOT LIMITED TO, PREEXISTING CONDITIONS (WHETHER SUCH CONDITIONS BE PATENT OR LATENT); THE UNSEAWORTHINESS OF ANY VESSEL OR VESSELS (WHETHER OR NOT PREEXISTING); THE UNAIRWORTHINESS OF ANY AIRCRAFT; BREACH OF REPRESENTATION OR WARRANTY (EXPRESS OR IMPLIED); BREACH OF CONTRACT; BREACH OF DUTY (STATUTORY, CONTRACTUAL, COMMON LAW OR OTHERWISE); STRICT LIABILITY; CONDITION OF RUIN OR DEFECTIVE PREMISES, EQUIPMENT, FACILITIES, OR APPURTENANCES OF ANY PARTY UNDER ANY CODE, LAW OR (WHETHER OR NOT SAID CONDITION IS PREEXISTING AND/OR LATENT, PATENT OR OTHERWISE); THE LOADING OR UNLOADING OF PERSONS OR CARGO; TORT; OR THE NEGLIGENCE OR FAULT OF ANY PARTY (AS DEFINED AT THE BEGINNING OF THIS ARTICLE 14; OR ANY OTHER THEORY OF LEGAL LIABILITY).

Seller's total responsibility for any claims, damages, losses or liability arising out of or related to its performance of this contract or the products or services covered hereunder shall not exceed the purchase price.

15. MODIFICATION, RESCISSION & WAIVER:

The terms herein may not be modified or rescinded nor any of its provisions waived unless such modification, rescission or waiver is in writing and signed by an authorized employee of Seller at its office in Houston, Texas. Failure of Seller to insist in any one or more instances upon the performance of any of the terms and conditions of the contract or the failure of Seller to exercise any of its rights hereunder shall not be construed as a waiver or relinquishment of any such term, condition, or right hereunder and shall not affect Seller's right to insist upon strict performance and compliance with regard to any unexecuted portions of this contract or future performance of these terms and conditions.

All orders must be accepted by an authorized employee of Seller. The rights and duties of the parties and construction and effect of all provisions hereof shall be governed by and construed according to the internal laws of the State of Texas. Any disputes which arise under this agreement shall be venued in the District Court of Harris County, Texas or in the Southern District of Texas.

**VALVES & MEASUREMENT**

3250 Briarpark Drive, Suite 300
Houston, Texas 77042
USA Toll Free 800 323 9160

For the most current contact and location information go to: www.c-a-m.com