

Watertight Manhole Covers

Fibrelite's watertight manhole covers are technically superior to any other composite or cast iron manhole covers.

The lightweight, non-bolting design includes a watertight gasket that prevents water intrusion.

Standard covers comply with DOT H20 load ratings.

Heavy duty covers are also available.

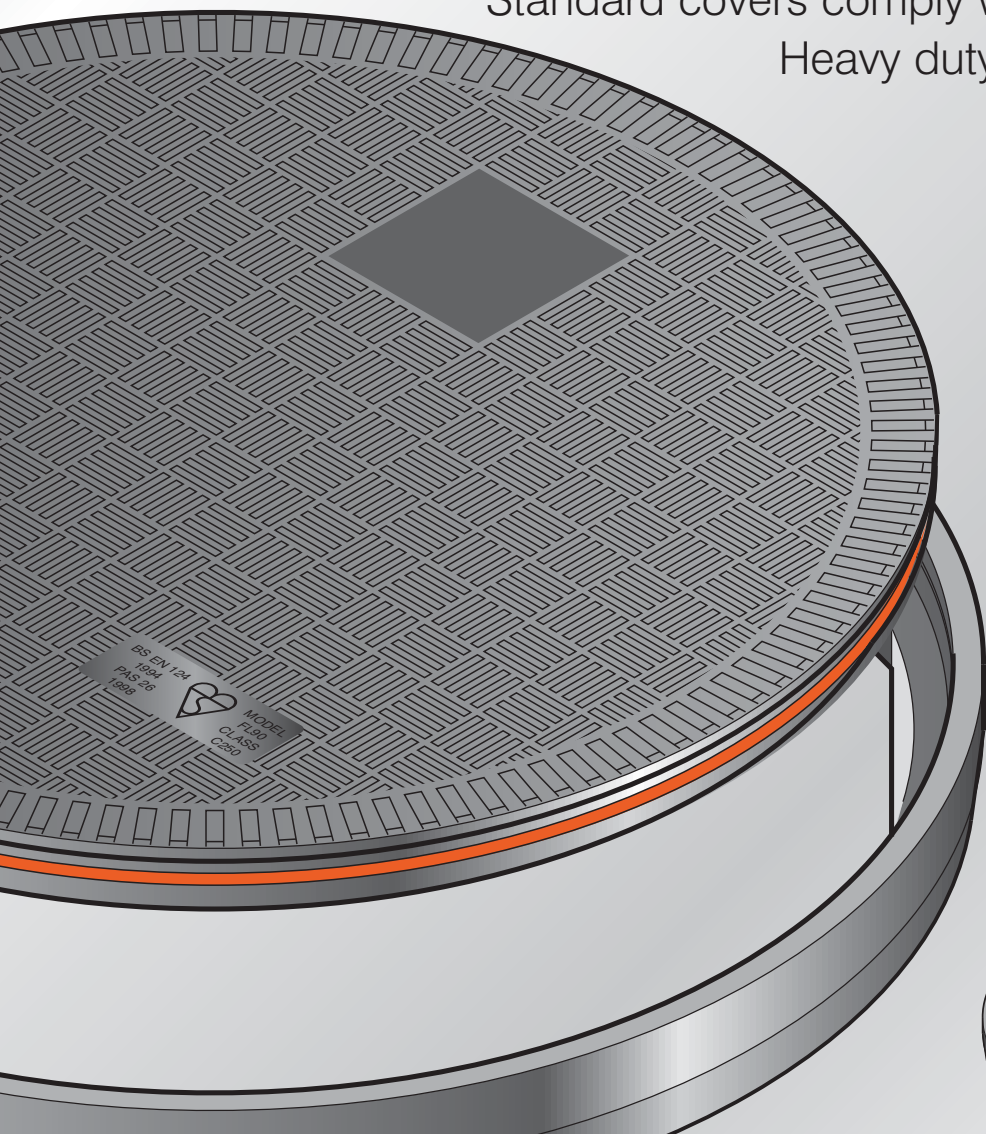

FIBRELITE

Shaping future standards

- Non-bolting design allows for quick access into sump.
- Covers are lightweight and are easily removed or replaced without risk of injury using a lifting handle.
- Completely watertight cover gasket.
- Gaskets can be easily replaced if damaged in field.
- Flush design allows for snowplowing and will not cause trip and fall injuries.
- Special anti-slip coating prevents slip and fall injuries.
- FRP skirts available to fit all models.
- Load tested to exceed H20 load ratings.
- Colors available for color coding to fuel grade.
- ID recess for API designation.
- Will not break or crack.
- Will not spin out.
- Tamper proof.
- Anti-static.



Fibresec
GROUP
COMPANY



FM 37923



FL760 - 30" dia. flat sealed cover

FL90 - 36" dia. flat sealed cover

FL100 - 40" dia. flat sealed cover

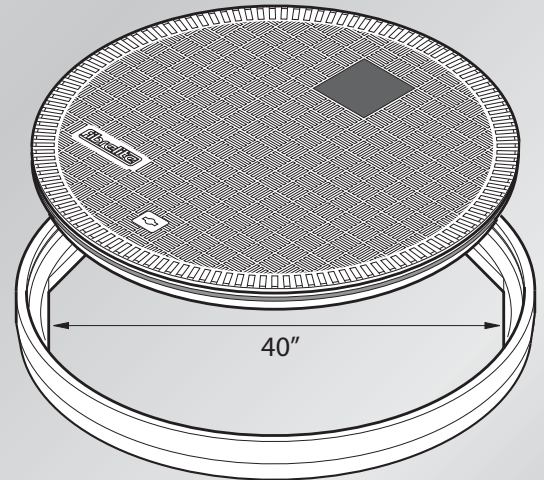
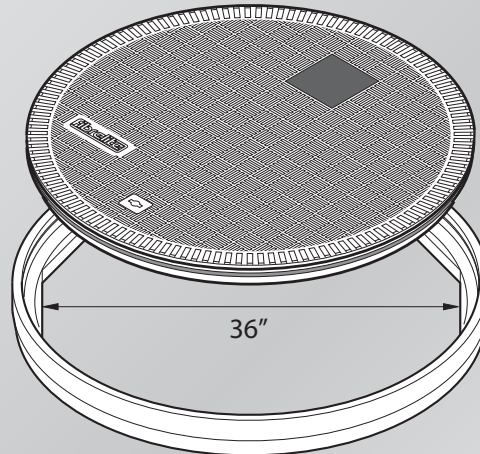
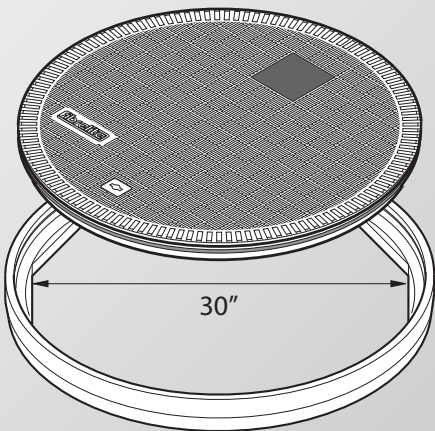

Use FL760 HD, FL90 HD or FL100 HD Heavy Duty covers in areas subjected to heavier loads (e.g. truck stops, bus depots).



US Office:

100 Mechanic Street, Pawcatuck, CT 06379, USA
Tel: +1 860 599 6081, Fax: +1 860 599 1037, E-mail: covers@fibrelitecorp.com

UK Office:

Snaygill Industrial Estate, Keighley Road, Skipton, North Yorkshire, BD23 2QR, UK
Tel: +44 (0)1756 799773, Fax: +44 (0)1756 799539,
E-mail: covers@fibrelite.com, Website: www.fibrelite.com