

BAUM KUNSTSTOFFE GMBH

Chemical resistant piping systems lined with PTFE-PFA-PP

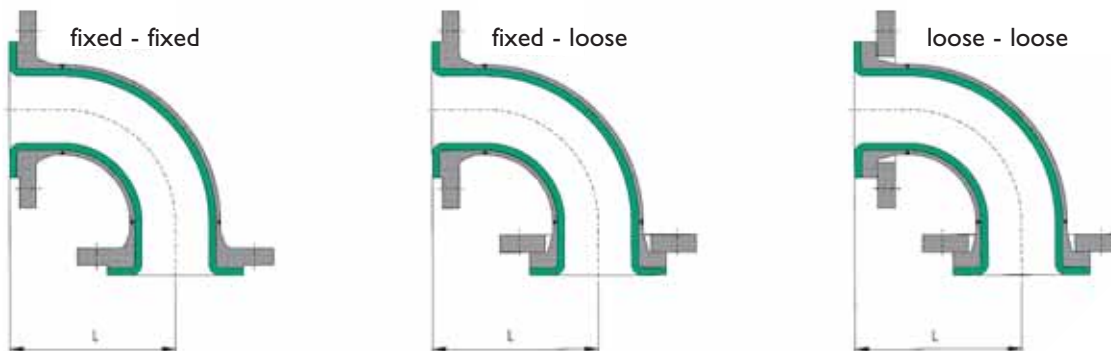

Elbows 90°



NPS	Class 150			Class 300			Form	Lining materials	
	L _{inch}	L _{mm}	Radius	L _{inch}	L _{mm}	Radius		PTFE	PP
1/2"	---	---	---	---	---	---	---	●	
3/4"	---	---	---	---	---	---	---	●	
1"	3.50	89	SR	4.00	102	SR	one-piece	●	●
1 1/4"	3.75	95	SR	4.25	108	SR	one-piece	●	
1 1/2"	4.00	102	SR	4.50	114	SR	one-piece	●	●
2"	4.50	114	SR	5.00	127	SR	one-piece	●	●
2 1/2"	5.00	127	SR	5.50	140	SR	one-piece	●	
3"	5.50	140	SR	6.00	152	SR	one-piece	●	●
4"	6.50	165	SR	7.00	178	SR	one-piece	●	●
5"	7.50	191	SR	8.00	203	SR	one-piece	●	
6"	8.00	203	SR	8.50	216	SR	one-piece	●	●
8"	9.00	229	SR	10.00	254	SR	one-piece	●	
10"	16.50	419	LR	16.50	419	LR	multi-part	●	
12"	19.00	483	LR	19.00	483	LR	multi-part	●	
14"	21.50	546	LR	21.50	546	LR	multi-part	●	
16"	24.00	610	LR	24.00	610	LR	multi-part	●	
18"	26.50	673	LR	26.50	673	LR	multi-part	●	
20"	29.00	737	LR	29.00	737	LR	multi-part	●	

The nominal pipe sizes 1/2" and 3/4" are not defined in the ASME B16.5. Please determine the desired length when contacting our sales force.

➔ Lined pipes, elbows, tees, instrument-tees, reducers, crosses and spacers in the dimensions DN15 to DN 500 and 1/2" to 20", according DIN 2848/2874 and ANSI B16.5 in carbon steel and stainless steel lined with PTFE, PFA (virgin, antistatic, FDA conformity upon request) and PP-lining.

➔ PTFE nozzle-liner and PTFE-lined steel dip pipes.

➔ Expansion joints in PTFE as well as stainless steel expansion joints with PTFE-lining.

➔ We also manufacture special forms and dimensions according to your requirements.

We are certified acc. DIN EN ISO 9001:2000.



Pressure Equipment Directive (PED 97/23/EG):

All piping parts fulfil the requirements of the PED and will be delivered with CE marking.

BAUM KUNSTSTOFFE GMBH

Gewerbestraße 25-29 • D-75217 Birkenfeld-Gräfenhausen
 Phone +49 (0) 70 82-94 36-0 • Fax +49 (0) 70 82-94 36-40
 E-Mail: info@baumkunststoffe.com • www.baumkunststoffe.com

