

## DN 500 MULTIDO™ Manlid 20" Low profile and Standard manlid

The PEROLO DN500 MULTIDO™ manlid is designed to be installed on containers, road tankers and storage tanks intended for chemical and foodstuff liquid products.

This product complies with ADR 2009 and EN 14 025.



### Specifications

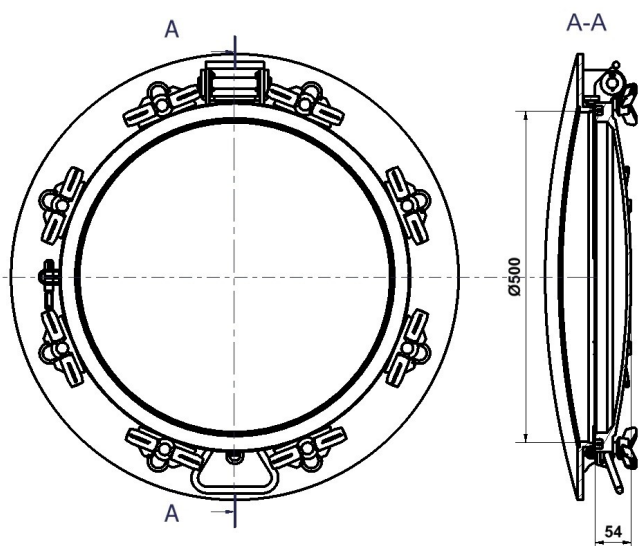

|                         |              |
|-------------------------|--------------|
| • Nominal Diameter :    | 500 mm (20") |
| • Weight                | 40kg         |
| • MAWP :                | 4 Bar        |
| • Test Pressure :       | 6 Bar        |
| • Designed temperature: | +200°C       |
| • Explosiveness :       | 11 bar       |

### Approval & Certifications

- Comply with IMDG & ADR.
- Comply with EN 14 025
- Approved by Lloyd's Register

### Features

- 316L stainless steel manlid & swingbolts
- Wide range of products for an easy adaptation
- Smooth machined internal surfaces
- Captivate handnuts
- Thread rolled eyebolts
- Trapezoïdal seal groove for a perfect tightness

### Options

- Material : 316L, 304L or 904L Stainless Steel, S355 carbon Steel
- MAWP : 2, 3 or 4 Bar.
- Number of fastening points : 6, 8, 10 or 14.
- Low profile, neckring height : from 21 to 34mm
- Standard, neckring height : from 36 to 300mm
- Neckring thickness : 6, 8, 10 or 14mm.
- Flush neckring.
- Protusion : from 3 to 6mm or flush neckring
- Radius : from 850 to 1200mm.
- Sealing : Standard or TIR
- Bolts : Standard swingbolts or Safetbolts
- Finishing : Acid Etched, electropolishing or Halar coated

### Accessories

- |                                  |                      |
|----------------------------------|----------------------|
| • 8 points Low profile Coverlid. | Part # CMS54D8SS     |
| • 6 points Low profile Coverlid. | Part # CMS53D6SS     |
| • 8 points Standard Coverlid.    | Part # CMS54D8DS     |
| • 6 points Standard Coverlid.    | Part # CMS53D6DS     |
| • Long eye bolt kit (83mm).      | Part#12 93 86 91 00. |
| • Short eye bolt kit (58mm).     | Part#12 93 86 92 00. |
| • Gasket PTFE/EPDM 14*14         | Part#11 13 75 00 19. |
| • Hinge kit Stainless steel      | Part#12 13 68 91 00. |

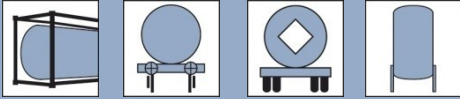

## Codification

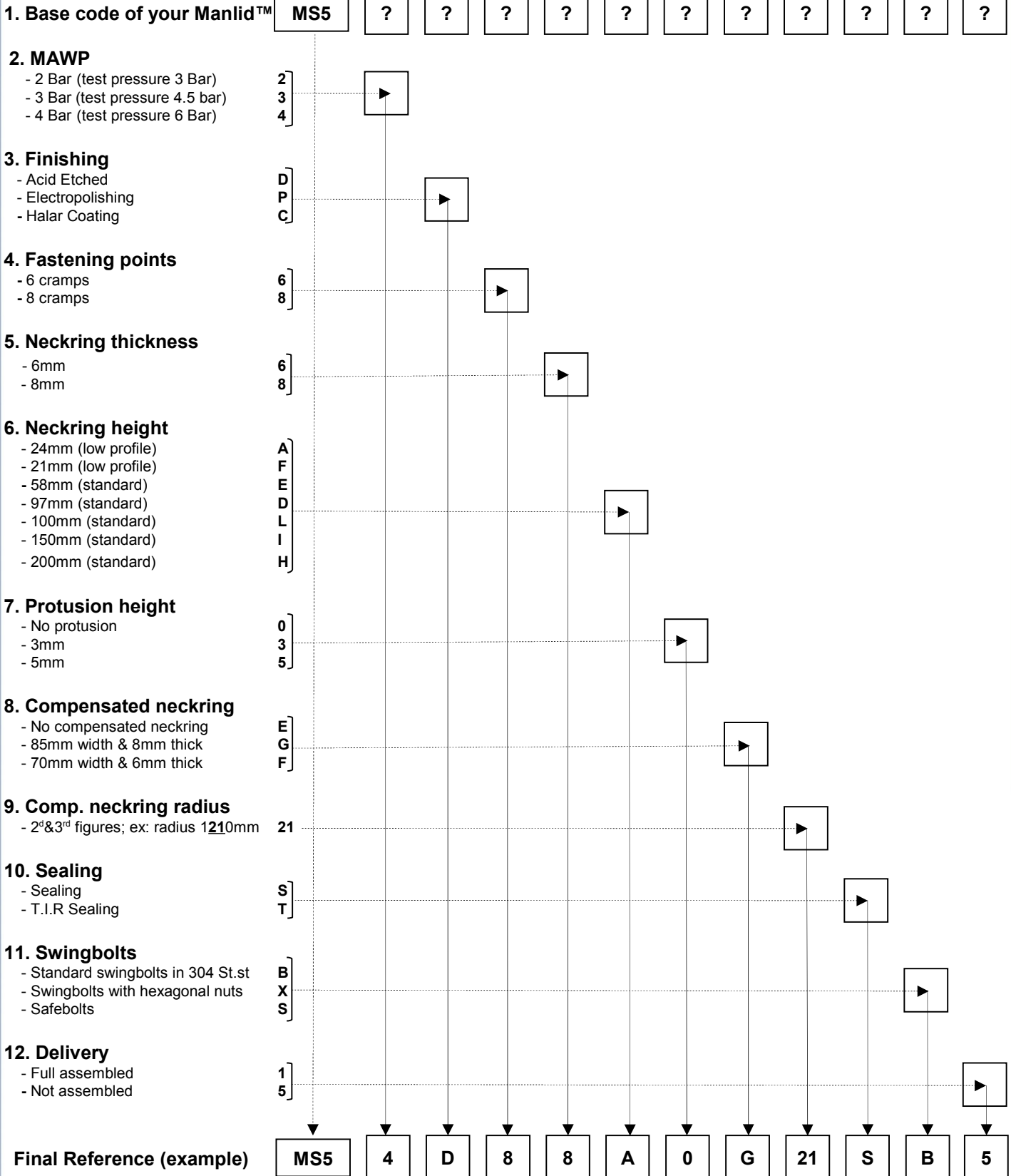

For any specific requests, please feel free to contact our sales department at [sales@perolo.com](mailto:sales@perolo.com)